

CCpilot XA
CCpilot XS
CrossCore XS

Technical Manual

maximatecc•

www.maximatecc.com

Contents

1. Introduction	4
1.1. Product models and options	4
1.2. Conventions and defines	5
1.3. Identification	5
1.4. Environment and Environmental Tolerance	6
2. Device overview	7
2.1. CCpilot XA overview	7
2.2. CCpilot XS overview	8
2.3. CrossCore XS overview	9
3. Installation and handling	10
3.1. Mounting	10
3.2. Grounding	11
3.3. Power supply installation	11
3.4. Cable installation	13
3.5. Antennas	13
3.6. SIM card installation	13
3.7. Environmental considerations	14
3.8. Handling and maintenance	15
4. Basic operations	16
4.1. Turning ON	16
4.2. Turning OFF	16
4.3. Adjusting the screen brightness	17
4.4. Using the touch screen	17
4.5. Status LED indicator	18
5. Interface overview	19
5.1. Storage memory	19
5.2. Front panel	19
5.3. Audio output	19
5.4. Analog video inputs	20
5.5. CAN	20
5.6. USB	20
5.7. Ethernet	20
5.8. Serial port (RS-232)	21
5.9. Digital I/O	21
5.10. GPS	21
5.11. GSM/GPRS	22
5.12. WLAN	22
5.13. Bluetooth	22
6. Connectors	23
6.1. Power supply	23
6.2. Serial port and Audio output	24
6.3. USB ports	24

6.4. Digital I/O	24
6.5. Analog video	24
6.6. CAN ports	25
6.7. Ethernet	25
6.8. GPS antenna.....	25
6.9. Bluetooth antenna.....	25
6.10. GSM/GPRS antenna	26
6.11. WLAN antenna	26
7. Specifications.....	27
7.1. Product models connectivity level	27
7.2. Technical data	27
7.3. Environmental specifications	30
7.4. Weight and dimensions	31
8. Technical Support.....	34
9. Trade Mark, etc.	35
10. Index	36

1. Introduction

CCpilot XA, *CCpilot XS* and *CrossCore XS* – all part of the CCpilot XA family – are on-board displays and controllers with a rich set of integrated functions and external interfaces.

The powerful ARM based CPU and Linux operating system constitutes an open platform that facilitates the implementation of premium user-machine interaction, reliable controls and integrated fleet management.

This technical manual provides important information regarding the device's hardware and its basic usage. For software and operating system specifics, please see additional documentation.

1.1. Product models and options

This documentation is applicable for all *CCpilot XA*, *CCpilot XS* and *CrossCore XS* models. The set of interfaces available for each model and option are listed in chapter 7.1 - *Product models connectivity level*.

Different variants are described below:



1.1.1. CCpilot XA and CCpilot XS

The *CCpilot XA* and *CCpilot XS* models offer the same level of performance and interfaces but form factor and display alternatives differ.

- *CCpilot XA* has a 7" display with projective capacitive touch-screen.
- *CCpilot XS* has a 10.4" display with resistive type touch-screen which can be operated also when wearing thick gloves.

Both *CCpilot XA* and *CCpilot XS* are available in several product variants, i.e. the *standard*, the *Net+* and the *All-Integrated* models:

- The *standard* model offers interfaces such as CAN, USB, Ethernet, Audio out, Analog video in, Serial port and Digital I/O.
- The *Net+* model differ from the *standard* model with additional number of CAN and USB interfaces and no support for Analog video and Digital I/O interfaces.
- The *All-Integrated* add-on – available for all models above. Adds the wireless interfaces GSM/GPRS, WLAN and Bluetooth for communication and GPS for positioning.



1.1.2. CrossCore XS

The *CrossCore XS* model is a controller model without display. Otherwise it has the same features and interfaces as the *CCpilot XA/XS Net+* models described above.



1.1.3. Customized models

The platform enables additional customization of hardware and software. Described herein are the features included using product models described above. Any additional feature will be described in model specific documentation.

1.2. Conventions and defines

CCpilot XA, CCpilot XS and CrossCore XS are in many cases identical in functionality and usage, besides the lack of display functionality in the CrossCore XS models.

The following definitions are used to separate model specific details within this document. The observe symbol is also used to highlight such difference.

Defines	Use
CCpilot XA	Information that is specific for CCpilot XA
CCpilot XS	Information that is specific for CCpilot XS
CrossCore XS	Information that is specific for CrossCore XS
All-Integrated	Information that is specific for All-Integrated models
Net+	Information that is specific for Net+ models
device	Information that applies to all models (or to specific models referred to within a section)

 The 'observe' symbol is used to highlight information regarding differences between product models and options.

 The 'A' symbol is used to highlight information specific for All-Integrated models.

 The 'exclamation' symbol is used to highlight information that is especially important for the end-user.

Different text formats used in this document are described in the table below:

Format	Use
<i>Italics</i>	<i>Names, designations and references.</i>
Bolded	Important information.

1.3. Identification

Each device has a label with article number, revision and serial numbers which identify your unique device. Take note of these numbers. During service and other contact with the supplier it is important to be able to provide this information.

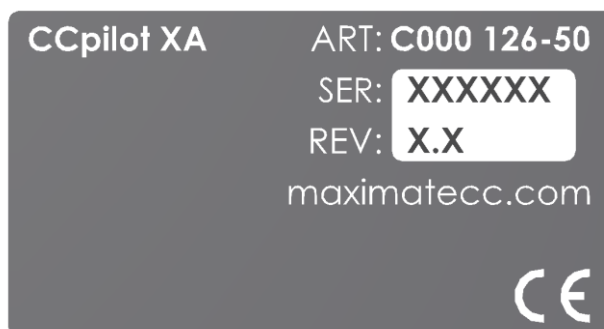

1.4. Environment and Environmental Tolerance

The device has been designed to cope with tough environmental demands. Much effort has been put into selecting and designing system components to provide you with a user-friendly working instrument that is reliable under all circumstances. Rigorous testing has been conducted in order to ensure compliance to a broad range of applicable regulatory requirements and to meet the user expectations of a ruggedized device for vehicle and machinery control.

A full list of standards to which the device has been tested for compliance can be found in *chapter 7.3 -Environmental specifications*.

2. Device overview

This chapter contains illustrations of the *CCpilot XA/XS* and *CrossCore XS* models showing the location of external connectors, indicators etc.

Additional mechanical information can be found in *chapter 7.4 - Weight and dimensions*.

Connectors are described in more detail in *chapter 6 - Connectors*.

 *CCpilot XA* and *CCpilot XS* devices illustrated below are the *standard* models. *Panel mounted* variants of those models are similar but with the additional option to be mounted in a flat panel cutout.

2.1. CCpilot XA overview

On the front side of the device there is a 7" display with a PCAP touch-screen, buttons for device on/off control as well as display brightness adjustment. There is also a buzzer, a Status LED indicator and a light sensor.



On the rear side of the device are the interface connectors. There are also mounting holes for fasteners in accordance with VESA 50.

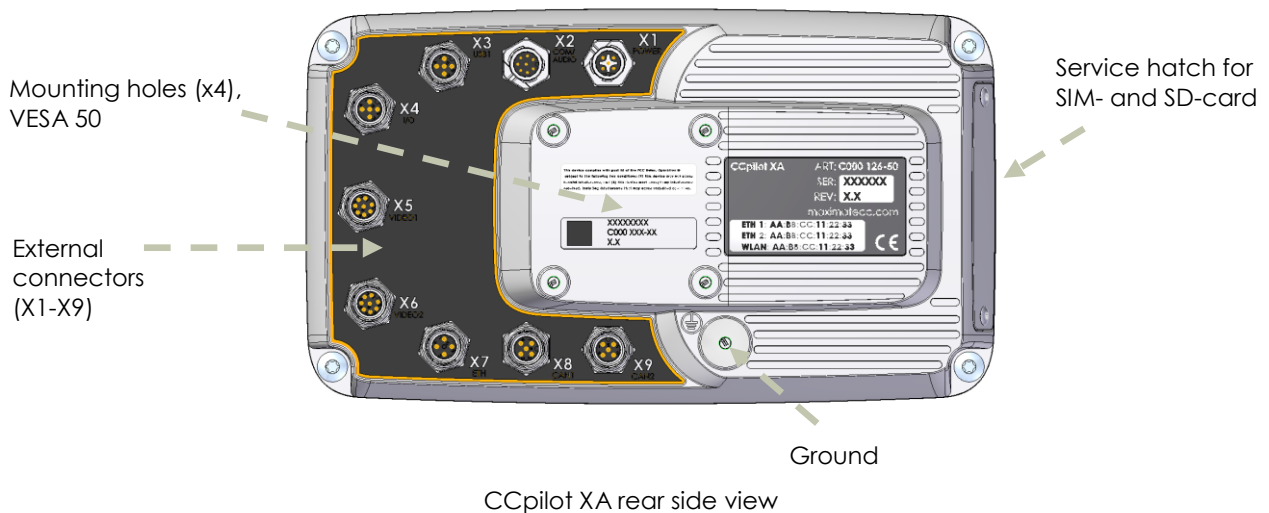

2.2. CCpilot XS overview

On the front side of the device there is a 10.4" display with resistive touch-screen, buttons for device on/off control as well as display brightness adjustment. There is also a buzzer, a Status LED indicator and a light sensor.



CCpilot XS front side view

On the rear side of the device are the interface connectors. There are also mounting holes for fasteners in accordance with VESA 50.

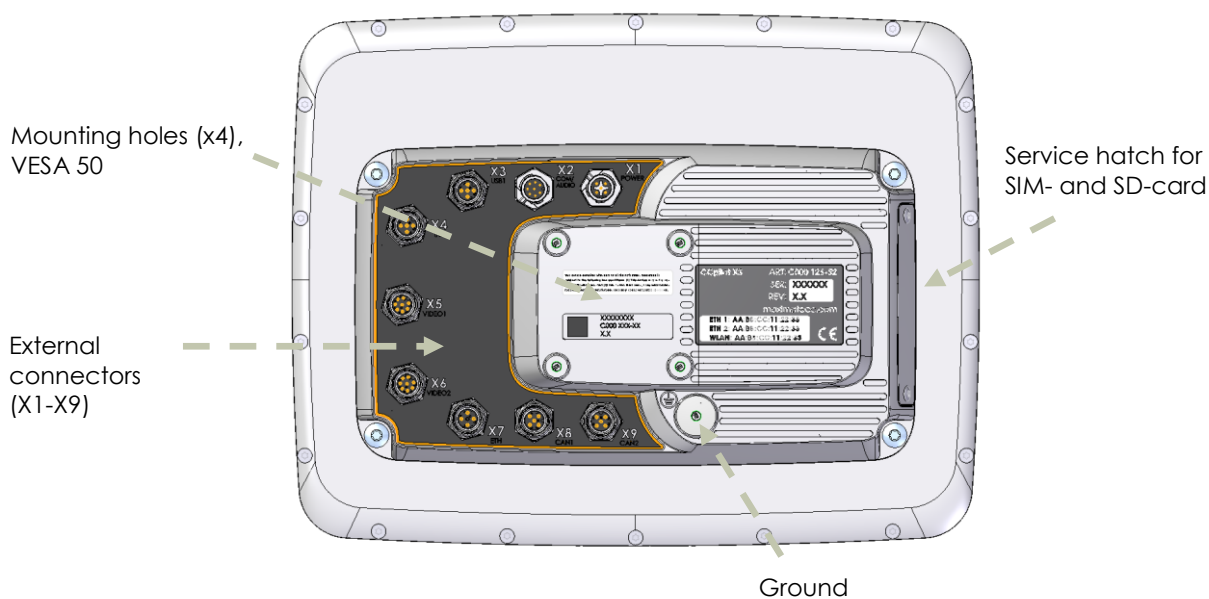

CCpilot XS rear side view



2.3. CrossCore XS overview

On the top side of the device are the interface connectors and a Status LED indicator. The connectors are described in more detail in *chapter 6 - Connectors*.

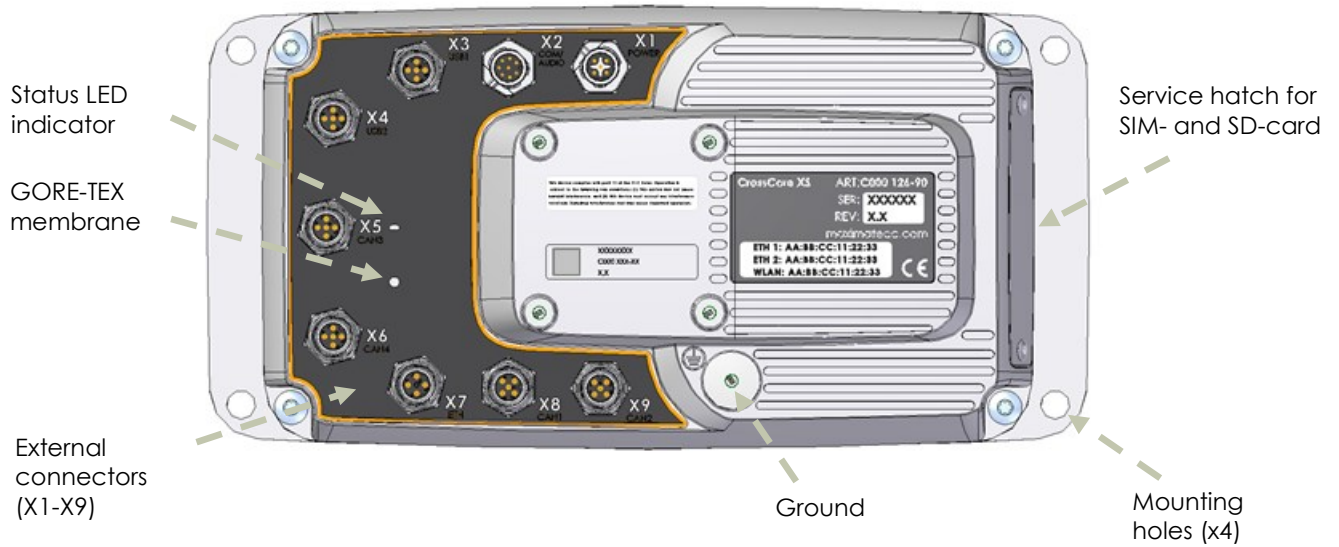

CrossCore XS top side view

3. Installation and handling

This chapter contains recommendations for installation, handling and maintenance of the device.

3.1. Mounting

3.1.1. CCpilot XA/XS

The *CCpilot XA* and *CCpilot XS* devices are preferably mounted on a VESA 50 bracket which allows adjustment of the display position and angle. Make sure that the bracket used is robust enough to withstand the weight of the device and the shocks and vibrations that the installation may be exposed to.



The enclosure has blind holes with a maximum thread depth of 9.5 mm. To fasten the device, apply thread locker (*Loctite 222*) in the threaded holes and use 4 x M5 cap screws of class 8.8 or higher, preferably of MC6S (Allen) or MRT (Torx) type. Apply a torque of about 5.3 Nm.

3.1.2. Panel mounted variants

Panel mounted product variants have the possibility to be mounted in a panel cutout as described below or to be mounted using standard VESA 50 brackets as described in *chapter 3.1.1*.

- Contact maximatecc for panel cutout drawings.

The device has countersunk mounting holes in the front panel (thickness: 5 mm).

To fasten the device, use 4 x M5 90° countersunk screws of grade 8.8 or higher. Thread locker (*Loctite 222*) is recommended to secure the mounting screws. Adequate mounting torque must be decided by the installer.



Observe that no mounting gasket for sealing the device against the panel is included. If the installation requires sealing, a gasket or sealant must be applied by the installer.

3.1.3. CrossCore XS

CrossCore XS is preferably mounted using the mounting holes on the base plate. See *chapter 2.3 - CrossCore XS overview*.



Ensure that the device is mounted to a flat surface. Fastening the unit to an uneven surface may stress the device and cause permanent damage.

To fasten the device, use 4 x M8 Allen screws of grade 8.8 or higher. Thread locker (*Loctite 222*) is recommended to secure the mounting screws. Adequate mounting torque must be decided by the installer.

3.2. Grounding



To ensure proper EMC performance and operation of the touch-screen interface, the device must be electrically bonded to system ground using a braided ground strap.

- Connect the device to the vehicle or machine ground structure via the device ground connection.
- Location of the ground connection can be found in *chapter 2 - Device overview*.
- The ground connection has a blind hole with a maximum thread depth of 9.5 mm.

Use a M5 cap screw of grade 8.8 or higher and apply a torque of 5.3 Nm. It is recommended to use thread locker to secure the screw and star washers to ensure proper electric contact between the device enclosure and external ground structures through the ground strap.



Observe that device chassis ground is internally connected to the negative main supply input. Be cautious not to create ground loops.

3.3. Power supply installation

This chapter describes installation of *CCpilot XA/XS* and *CrossCore XS* devices in vehicles or other machines. The principle is the same also for other types of installations.

For connector pinout, see *chapter 6 - Connectors*.

Before installing the device into a vehicle or other machinery, carefully read through the instructions below:

- Make sure that device grounding is properly applied. See *chapter 3.2 - Grounding* for details.
- Wire gauge for the supply input shall be dimensioned with respect to cable length, supply voltage, maximum allowed voltage drop and maximum current consumption of the load.
 - As a guideline, the recommended minimum cable area per device is:
2 x 0.34 mm² (2 x AWG 22) or
1 x 0.75 mm² (1 x AWG 18)



- When connecting the device to a vehicles or machines battery (or other power source with high current capabilities), always apply fusing to prevent cable fire in case of short circuit.
 - The fuse shall be located as close to the battery/power source as possible.
 - Fuse rating shall be dimensioned with respect to wire gauge and maximum current consumption of the attached load. Inrush current to the load shall also be taken into account. Refer to *chapter 7.2 - Technical data* for fuse rating details.
- The device's external on/off control signal (power connector - pin 5) should be connected to the positive supply line via the vehicles turnkey switch or separate on/off switch (see "S2" in schematic below).
 - Remember to apply fusing also to the on/off control signal.
 - Several devices may be controlled by the same external on/off switch by joining their on/off control signals. The current drawn by the input (when high) is 0.5 mA for each device attached. The fuse rating and wire gauge shall be dimensioned for the total switch current.

- If the vehicle or machine has a main power switch (see “S1” in schematic below), the device’s power supply and on/off signal shall be connected after this switch. Observe that this switch shall **not** be used for switching the device on/off during normal operation. It is only intended for disconnecting the battery to prevent draining of the battery during prolonged stalling intervals of the vehicle or machine.

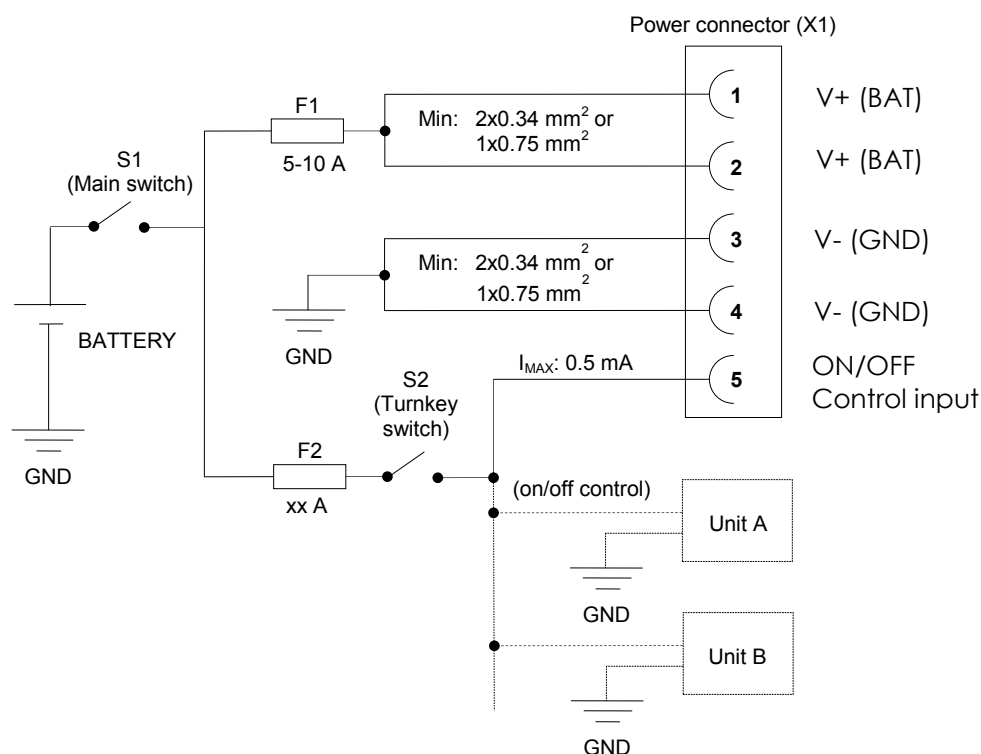

Schematic example for power supply installation of *CCpilot XA/XS* and *CrossCore XS* devices in vehicles or other machines. The on/off control switch (S2) is shared by several devices (Unit A, Unit B etc.).

By connecting the power supply according to the illustration above, with the main switch S1 normally closed, the device will automatically start when the turnkey switch S2 is turned on and shut down when the switch is turned off.



3.3.1. Precautions

Ensure that the device is shut down using the front panel on/off button or turnkey functionality before turning off the main switch or in any other way making the computer powerless. Ensure that any application data is saved before turning off the device.

- Sudden power disruptions (longer than ~ 0.1 seconds) may cause the device to shut down, potentially causing lost or corrupt data. If for example the power supply voltage fluctuates significantly when starting the vehicle engine, the device should be started after the vehicle engine has been started.

- During welding or other service on the machine, all cables to the device shall be disconnected.
- Be advised that the device consumes a small amount of power from the main supply also when shut-down (~1 W). In vehicle installations, if the device has been attached for a long period of time without the vehicle motor running, the battery may be drained, resulting in inability to start up the vehicle. A main switch for disconnecting the device's main supply is recommended in such situations.

3.4. Cable installation

Cables shall be installed in such a way that they don't run any risk of being damaged, pinched or worn.

- Avoid excessive bending and twisting of cables.
- Use strain-relief on cables near the device to minimize stress on cables and connectors.
- Shielded cables are recommended to ensure reliable communication and compliance to industrial EMC standards.
 - Avoid ground loops by directly connecting cable shields at one end only.
- To ensure IP-classification of the cable connectors:
 - Make sure that connector O-ring gaskets are in place and intact before attaching cables or protective caps.
 - Cable-side connectors must be properly screwed to the device.
 - Unused connectors must be secured with sealing protective caps.

3.5. Antennas

There are no internal antennas for wireless interfaces in the *All-Integrated* product models. External antennas must be attached to use the wireless interfaces.

Observe that extension cables are required for sufficient separation of external antennas in systems utilizing more than one wireless interface. This must be followed to comply with regulations for maximum RF exposure (SAR levels) and for reliable operation of the interfaces.



- Antennas **must not** be located within 20 cm from any person or co-located within 20 cm of another antenna or transmitter.

For more information regarding antenna type and maximum gains allowed, see chapter 5 - *Interface overview*.

3.6. SIM card installation

Installing the SIM card for the GPRS/GSM functionality requires the service hatch on the side of the device to be opened.

The following procedure describes how to insert and replace the SIM card:



- Make sure that the device is powered off and placed in a clean, dry and ESD-protected area.

- Remove the 2 screws holding the service hatch in place using a Torx (T9) screw driver and remove the hatch.
 - Pay attention not to damage the gasket located on the service hatch.
- Locate the SIM card holder (see figure below) and insert the SIM card. The SIM card must be inserted fully by pushing it to the bottom of the card holder until a clicking sound is heard, and then released.

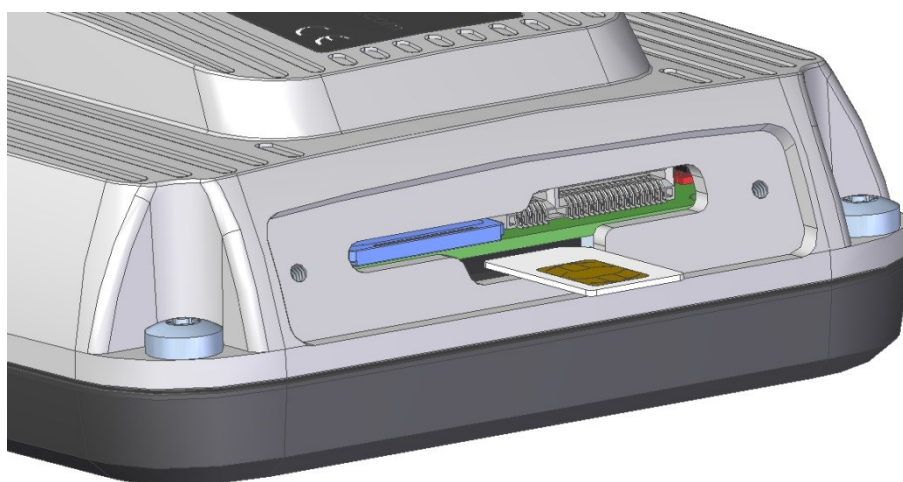

- The SIM card is removed again by pushing it to the bottom of the card holder after which it can be pulled out for removal.
- Make sure that the service hatch gasket is not damaged, and then re-assemble the unit in reverse order.
 - Apply thread locker (*Loctite 222*) before applying the screws.



3.7. Environmental considerations

To ensure proper and reliable operation of the device, follow the recommendations below:

- The device shall be placed in a way that prevents the unit from direct exposure to water or sunlight.
- To enable sufficient cooling, the device must be installed to allow ambient air to circulate around it. A clearance of at least 50 mm around the device is recommended.
- Avoid installing the device near hot air vents or in direct sunlight.
- To maintain the device's IP classification, protective caps must be attached to unused connectors.
- Each device has a GORE-TEX® membrane for ventilation; see location in *chapter 2 - Device overview*. For proper ventilation of the device, dirt and water must be prevented from accumulating and covering the membrane. Be cautious not to insert objects which may puncture or detach the membrane. Doing so will violate the IP-classification and void the warranty of the device.

- Loose mounting bolts are a common cause for excessive vibration. They may come loose due to improper mounting techniques such as omitting thread locker or lock washers, over- or under-tightening. Proper tightening requires clean dry bolts and a torque wrench.
- Install the device and its cables in such a way that they are not subject to excess vibrations or other mechanical stress.

3.8. Handling and maintenance



Handle the device with care and pay attention to the following handling directives:

- Disconnect all cables to the device during welding or when performing other service to the machine imposing a risk of damaging electronic devices.
- Service and repair to the device shall only be made by authorised personnel. If the device is opened by unauthorised personnel, its warranty will be voided.
- Scratches or other damages may occur to the display surface if it is exposed to sharp objects or heavy impacts. This must be avoided to increase the longevity of the screen.
- The internal Flash memory (SD-card) has a limited number of write cycles. It is recommended that the amount of writing to flash storage is limited within software applications.
- Always consider personal safety when installing and operating the device. For example, in vehicle installations, maximatecc does not recommend that the device is being actively operated by the driver when a risk of injury to people or damage to property is present.

3.8.1. Cleaning



To ensure proper and reliable functionality over time, pay attention to the following cleaning instructions and precautions:

- Wipe the device clean from dirt using a soft, light damp cloth, preferably of *microfiber* type.
- Avoid using alkaline, alcoholic or other chemicals for cleaning; doing so may damage the device. However, small amount isopropyl alcohol may be used for removing harsh stains.
- Never spray or apply water or alcohol directly to the device. Instead, dampen the cloth lightly before using it for cleaning the device.
- After cleaning, make sure that the device surface is left dry.
- Never use high-pressure air, water or steam to clean the device.

3.8.2. RTC clock back-up battery

Time and date information is stored in a memory sustained by a back-up battery.



The expected life time of the battery is approximately 10 years. Contact maximatecc for instructions of replacing the battery.

4. Basic operations

This section covers basic operation of the device such as start-up, shut-down, display operation and status indication.



Observe that the behaviour of both the on/off controls (front panel button and external on/off control) is user configurable in terms of:

- Enabling/disabling functionality
- Configurable timing parameters

Also observe that the Status LED behaviour in the operational state of the device is configurable by user applications. Described herein are the factory default behaviours of the on/off controls and the Status LED.

4.1. Turning ON

CCpilot XA and CCpilot XS devices can be started up in two ways:

1. By a positive transition of the power connector on/off control signal. For more information see *chapter 3.3 -Power supply installation*.
 - When started this way, the on/off signal must remain asserted. De-assertion will shut down the device.
2. By a short press of the front panel on/off button.



CrossCore XS devices can only be started by method nr. 1 described above.

While starting up the devices, the Status LED will flash YELLOW (2 Hz). The Status LED stops flashing and enters a constant GREEN light once the device enters operational state.

4.2. Turning OFF



To ensure that data does not get lost or the flash memory becomes corrupt, it is recommended that all necessary data shall be saved and all programs closed before the device is shut down.

There are a number of ways to turn off the device:

1. By holding the power connector on/off signal low (below approximately 3.5 V) for more than 4 seconds.
 - When shut down this way, if the on/off signal is brought back high again, the device will automatically restart once the shutdown has been completed.
2. By a short press of the front panel on/off button (available on CCpilot XA/XS devices only).
 - A long press (more than 8 seconds) causes a forced shutdown, see *chapter 4.2.1 - Forced Shutdown* for details.
3. By the operating systems shutdown alternatives.



While shutting down, the status LED will enter a constant YELLOW light. When completely shut down, the Status LED will stop lighting.

4.2.1. Forced Shutdown



For *CCpilot XA/XS* devices, if the device is not responding, a forced shutdown can be performed by pressing and holding the front panel on/off button until the device is switched off - indicated by the Status LED stops lighting/flashing.

- The default button-press time for performing a forced shutdown is 8 seconds.



A forced shutdown immediately shuts down the device, regardless of its operational state. Any information which was not saved will be lost when performing a forced shutdown. Any ongoing writing to the SD flash memory will be disrupted which may lead to a corrupted file system.

- Therefore it is **not** recommended to use the forced shutdown feature unless absolutely necessary.

4.3. Adjusting the screen brightness



This chapter applies to *CCpilot XA* and *CCpilot XS* devices only.

Use the front panel brightness buttons to gradually increase or decrease the display brightness.

The screen brightness can also be controlled from software, which also allows for automatic adjustment of the brightness using the front panel light sensor.

There is also possible to apply the same brightness adjustment for the Status LED.

4.4. Using the touch screen



This chapter applies to *CCpilot XA* and *CCpilot XS* devices only.

The display is equipped with a touch functionality which gives the opportunity to provide a very easy-to-use HMI (Human Machine Interface) for the user.



Observe that for the touch screen interface to operate properly, the device must be properly connected to the ground structure of the vehicle or machine. This is extra important for devices equipped with a capacitive touch-panel. For details, see *chapter 3.2 - Grounding*.

4.4.1. Touch screen double- and right-click operation

Double click is performed similar to using an external pointing device. Tap the screen twice in the same place.

Tap and hold the touch screen to perform a “right-click” operation.

4.4.2. Touch screen calibration

Touch screen calibration can be started from the CCsettings software API.

For detail, see software documentation.

4.5. Status LED indicator

The Status LED indicator on the device indicates different operational states using colours and flashing patterns.

Table below describes the *default* behaviour of the Status LED for different operational states:

Operational state	Status LED behavior
Device off	Off
Starting up	Flashing YELLOW, 2 Hz
Operating (started up)	Constant GREEN light
Shutting down	Constant YELLOW light
Internal heating activated	
- Until lower temperature limit for start-up is reached.	Flashing YELLOW, 1 Hz
Entering forced shutdown	
- During first 4 seconds	Constant YELLOW
- After 4 seconds	Flashing YELLOW, randomly
- After 8 seconds	Off (device is not switched off)



Observe that the Status LED behaviour in the *operating* state is configurable by user applications running on the device.

The Status LED is also used for error-codes; refer to software documentation for details.

5. Interface overview

This section describes the various interfaces of the device. Note that, depending on product model, all interfaces may not be present. See *chapter 7.1 - Product models connectivity level* for information about respective model configuration.

5.1. Storage memory

An industrial grade SD-card is used for data storage. This makes the device resilient to shock and vibrations which would be a problem when using mechanically rotating hard disks.



The Flash module is industrial grade classified and has both static and dynamic wear levelling to prevent premature wear-out and to extend the lifetime of the memory. Still it has a limited number of write cycles. It is recommended that the amounts of writing to storage are limited within the software applications.

5.2. Front panel



This chapter applies to *CCpilot XA* and *CCpilot XS* devices only.

5.2.1. Status LED

There is a user configurable multicolor Status LED for indication. See *chapter 4.5 - Status LED indicator* for details.



In *CrossCore XS*, the Status LED is located at the connector-side panel.

5.2.2. Light sensor

There is a light sensor in the front panel which can be used by user applications to enable automated dimming of the display brightness.

5.2.3. Buzzer

There is a buzzer in the front panel that can be used for audible notifications. The buzzer is application controllable with configurable volume and frequency.

5.3. Audio output

There is an analog audio output which can be used for playing everything from warning sound to music when the device is connected to a sound system.

The output offers a line-out stereo signal with volume setting controlled through the operating system. The connector is shared with the RS-232 serial port.

5.4. Analog video inputs



Observe that analog video is not available on *CrossCore XS* and *Net+* models.

There are a total of four analog video inputs using two M12-connectors with two video inputs each. The inputs are used for attaching analog video sources such as rear view- and surveillance cameras.

The analog video inputs support PAL as well as NTSC video formats.

Each video channel has a 12 V_{DC} power supply output with individual on/off control.

- The video power outputs have a combined current limit giving a maximum output current of 500 mA (sum of all outputs).
- In case of short circuit or over-current condition, all four outputs will switch off.

The cable which is used to connect the camera to the device shall be a 75 Ω coaxial cable, for example: M17/94-RG179. Shielded cables shall be used to ensure electromagnetic compliance.

5.5. CAN

The CAN ports are in accordance to CAN ISO 11898 2.0B with M12 connector pinout according to the CANopen standard.

Each CAN port is galvanically isolated from chassis ground and is tolerant for bus short-circuits. There is no device-internal CAN bus termination; therefore bus termination must be applied externally.

5.6. USB

The USB ports follow the USB 2.0 standard.



- Due to limitation in the M12 connector specification, USB data signal integrity cannot be guaranteed with higher speeds than full-speed USB (12 Mbps). Though, hi-speed operation is supported by the USB host controller.

The USB ports can supply up to 500 mA each. The USB ports are internally over current and short circuit protected. Shielded cables shall be used to ensure reliable communication and electromagnetic compliance.



Note that *CCpilot XA/XS* standard models have one USB port while *Net+* and *CrossCore XS* models have two USB host port.

5.7. Ethernet

The device has an Ethernet interface supporting 10BASE-T/100-BASE-TX and Auto-MDIX with 500V_{AC}/707V_{DC} galvanic isolation.



Observe that:

- The Ethernet interface has *function isolation* only and must be connected to other SELV (Safety Extra Low Voltage) circuits only; i.e. local network without routing to outside plant.
- Shielded cables shall be used for this port to ensure reliable communication and electromagnetic compliance.
- Connecting the device to a public network environment may impose a security threat.

5.8. Serial port (RS-232)

The serial port follows the RS-232 standard but with a limited set of signals. The connector is shared with the Audio output. For details, see *chapter 6.2 - Serial port and Audio output*.

The serial port is galvanically isolated from chassis ground and supports bitrates up to 230 kbps.

5.9. Digital I/O



Observe that Digital I/O is not available on *CrossCore XS* and *Net+* models.

There are four digital I/O channels available. Each I/O channel is an active low open-drain signal with internal pull-up (10 kΩ to 5 V). This means that the I/O channels are logically inverted (*low* when asserted).

The momentary state of each I/O channel is sensed and can be read by user applications, regardless if it is used as an input or an output.

- When used as output, each I/O channel can be used for low-side switching of resistive, capacitive and inductive loads with a maximum current of 500 mA per channel.
 - Assert the output (*low*) to switch ON the load.
 - De-assert the output (*high*) to switch OFF the load.
- When used as input, the output control must first be switched off (set to *high* state). Then the input can be asserted (*low*) externally by pulling the signal to I/O-ground.

The Digital I/Os are galvanically isolated from chassis ground and use a common ground reference signal. They are protected for ESD, over-current and short-circuits to voltages between -36 to +36 VDC referred to I/O-ground.



Observe that high continuous current through several I/O channels simultaneously adds to the internal heating of the device. At high ambient temperatures, this may cause I/Os to switch off because of over-heating protection in their internal circuitry. When cooled down the output will automatically switch on again.

A 5.10. GPS

The internal GPS receiver in *All-Integrated* models follows the NMEA-0183 (rev. 3.01) standard. This is a common standard which is supported by most GPS technology softwares.

In order for the internal GPS receiver to operate, it requires an active GPS antenna to be connected to the device.

The antenna shall have the following specification:

GPS antenna requirements	
Type	Active, 50 ohm
Supply voltage	3.0 - 3.3V (bias voltage supplied by the GPS receiver)
Current consumption	40 mA (max)
Gain	0 dB to + 30 dB (10-25 dB preferred)

A 5.11. GSM/GPRS

The All-Integrated models have a GSM/GPRS modem for data connections. The modem supports quad band (850/900/1800/1900 MHz) and GPRS class 10 which gives a maximum transfer speed of 85,6 Kbit/s.

The modem uses an external antenna with an impedance of 50 Ω and a maximum gain of 1.4 dBi at 850 MHz and 3 dBi at 1900 MHz. The antenna shall not be co-located within 20 cm from any other transmitter or person.



If using an antenna with higher gain or locating it within 20 cm of a person or another transmitter, additional FCC/IC testing is required for operating the interface in the US or Canada market.

A 5.12. WLAN

The All-Integrated models support WLAN, interoperable with the standard 802.11 b/g wireless networks.

It delivers data rates up to 54 Mbps and supports a number of security standard protocols for a safe wireless connection.

The WLAN antenna shall be of monopole type with an impedance of 50 Ω and a maximum gain of 3 dBi. The antenna shall not be co-located within 20 cm from any other transmitter or person.



If using an antenna of other type, with higher gain or located it within 20 cm of a person or another transmitter, additional FCC/IC testing is required for operating the interface in the US or Canada market.

A 5.13. Bluetooth

The All-Integrated models have HCI Bluetooth support. HCI stands for Host Controller Interface and provides a uniform interface method for accessing Bluetooth hardware capabilities. The Bluetooth module complies with the Bluetooth 2.1 standard.

The Bluetooth module is of class 1 type, with a communication range of up to 100 m. The antenna shall be of dipole type with an impedance of 50 Ω and have a maximum gain of 2.14 dBi. It shall not be co-located within 20 cm from any other transmitter or person.



If using an antenna of other type, with higher gain or located within 20 cm of a person or another transmitter, additional FCC/IC testing is required for operating the interface in the US or Canada market.

6. Connectors

This chapter describes the pinout of external connectors of the device. For identification, each connector is marked with the letter 'X' followed by consecutive numbers starting at '1'. There is also a short descriptive text; for example: X1 POWER, X2 COM/AUDIO, etc.



- A table of connector identifiers (X1-X13) for each product instance is found in *chapter 7.1 - Product models connectivity level*.

Device connector are of the *Phoenix Contact SPEEDCON* series allowing quick locking when mated with cable-side connectors from matching series.



Each connector must either be equipped with a mating connector or a protective cap in order for them to meet their environmental tolerance. Also check that O-ring gaskets are in place and undamaged before attaching cables or protective caps.

Use caution and avoid plugging/unplugging of connectors when the computer is powered up. Always replace damaged cables. If a connector pin becomes bent the interface may not function correctly and the device should be returned to the manufacturer for repair.



Note that descriptions herein refer to the connectors located on the device and not the cable-side connectors which are attached to the device. Though, the pinout numbering and signal descriptions are the same.

6.1. Power supply

Pin #	Default signal	Comments
1	+10...+30 VDC	Main Power Input
2	+10...+30 VDC	Main Power Input
3	GND	Main Ground Input
4	GND	Main Ground Input
5	ON/OFF	ON/OFF control input

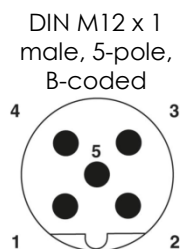

6.2. Serial port and Audio output

Pin #	Default signal	Comments
1	Audio out - Right	Right channel out
2	RS-232 – RxD	Serial "receive" input
3	RS-232 – TxD	Serial "transmit" output
4	Audio GND	-
5	RS-232 – GND	Serial port ground (floating)
6	Audio L out	Left channel out
7	RS-232 – RTS	Serial "request to send" output
8	RS-232 – CTS	Serial "clear to send" input
Housing	Shield	Cable shield

DIN M12 x 1
 male, 8-pole,
 A-coded

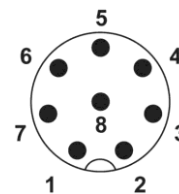

Note that the serial port is galvanically isolated from chassis ground.

6.3. USB ports



Second USB port (X4 – USB2) is only available on *Net+* and *CrossCore XS* models.

Pin #	Default signal	Comments
1	USB VBUS	5 V output, max 500 mA
2	USB D-	USB data - signal
3	USB D+	USB data + signal
4	-	-
5	USB GND	Ground
Housing	Shield	Cable shield

DIN M12 x 1
 female, 5-pole,
 A-coded

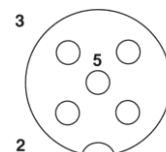

6.4. Digital I/O



Digital I/O is not available on *Net+* and *CrossCore XS* models.

Pin #	Default signal	Comments
1	DIO 1	Digital I/O channel 1
2	DIO 2	Digital I/O channel 2
3	DIO 3	Digital I/O channel 3
4	DIO 4	Digital I/O channel 4
5	DIO GND	Digital I/O ground reference
Housing	Shield	

DIN M12 x 1
 female, 5-pole,
 A-coded

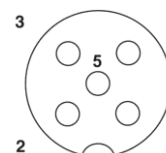

Note that the digital I/Os are galvanically isolated from chassis ground using a shared ground reference.

6.5. Analog video



Analog video is not available on *Net+* and *CrossCore XS* models.

Pin #	Default signal	Comments
1	Video Signal -	Video GND channel 1 or 3
2	Video Signal +	Video signal channel 1 or 3
3	PWR out +	Power out 12V channel 1 or 3
4	PWR out -	Power out GND channel 1 or 3
5	PWR out -	Power out GND channel 2 or 4
6	Video Signal -	Video GND channel 2 or 4

DIN M12 x 1
 female, 8-pole,
 A-coded

7	Video Signal +	Video signal	channel 2 or 4
8	PWR out +	Power out 12V	channel 2 or 4
Housing	Shield	Cable shield	-

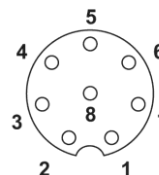

6.6. CAN ports

Observe that CAN3 and CAN4 interfaces are only available on *Net+* and *CrossCore XS* models.

Pin #	Default signal	Comments
1	CAN Shield	Connected to chassis ground
2	-	Not connected
3	CAN_GND	CAN ground reference
4	CAN_H	CAN high
5	CAN_L	CAN low
Housing	Shield	Cable shield

DIN M12 x 1 female, 5-pole, A-coded

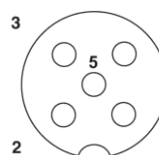

6.7. Ethernet

Pin #	Default signal	Comments
1	Tx+	-
2	Rx+	-
3	Tx-	-
4	Rx-	-
Housing	Shield	Connected to chassis ground

DIN M12 x 1 female, 4-pole, D-coded

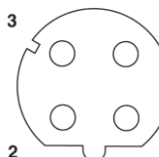

6.8. GPS antenna

Pin #	Default signal	Comments
1	Antenna signal	RF in/out
Housing	Antenna ground	RF ground

SMA, female, 50 ohm

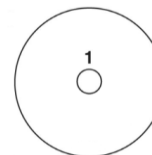

6.9. Bluetooth antenna

Pin #	Default signal	Comments
1	Antenna signal	RF in/out
Housing	Antenna ground	RF ground

SMA, female, 50 ohm

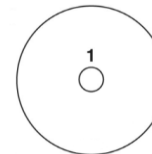

6.10. GSM/GPRS antenna

A

Pin #	Default signal	Comments
1	Antenna signal	RF in/out
Housing	Antenna ground	RF ground

SMA, female,
 50 ohm

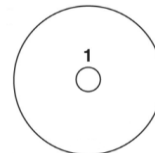

A

6.11. WLAN antenna

Pin #	Default signal	Comments
1	Antenna signal	RF in/out
Housing	Antenna ground	RF ground

SMA, female,
 50 ohm

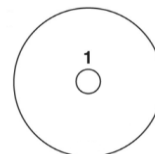

7. Specifications

The specifications may vary depending on your computer configuration.

7.1. Product models connectivity level



External interfaces available for each product model are listed in the table below:

Model	CCpilot XA and CCpilot XS models	Net+ and CrossCore XS models	All-Integrated models
Interfaces			
Power	1 (X1)	1 (X1)	-
CAN bus	2 (X8, X9)	4 (X8, X9, X5, X6)	-
USB Host	1 (X3)	2 (X3, X4)	-
Ethernet	1 (X7)	1 (X7)	-
Serial Port	1 (X2)	1 (X2)	-
Video In	4 (X5, X6)	-	-
Audio Out	1 (X2)	1 (X2)	-
Digital In/Out	4 (X4)	-	-
Wireless interfaces			
GPS	-	-	YES (X11)
Bluetooth	-	-	YES (X12)
GPRS	-	-	YES (X13)
WLAN	-	-	YES (X14)

7.2. Technical data

Temperature specification	
Operating	
Standard models	-25 to +70 °C
All-Integrated models	-25 to +60 °C (limited by WLAN module specification)
Storage	-40 to +85 °C

Kernel	
Processor	32-bit ARM, Freescale i.MX537, 800 MHz
Data storage	4 GB, Industrial grade SD card ^(Note)
RAM memory	256 MB, DDR3



(Note) The Flash module is industrial grade classified. It has both static and dynamic wear levelling to prevent a premature aging and to extend the lifetime of the memory. Still it has a limited number of write cycles. It is recommended that the amount of writing to flash storage is limited within the software applications.

Power Supply	CCpilot XA CCpilot XS	CrossCore XS
Supply Voltage		
Nominal	12 V _{DC} or 24 V _{DC}	
Extreme	10* V _{DC} ...34 V _{DC}	
* Down to 6 VDC with reduced operation (display and power outputs automatically switched off to reduce input power)		
Power Consumption		
Typical operating	5...25 W	4...15 W
Max operating	≈ 45 W	≈ 20 W
Shutdown	≈ 1 W	≈ 1 W
Inrush current		
@ 24 V _{DC} input	Up to 2.5 A (for < 120 ms)	
@ 12 V _{DC} input	Up to 5.0 A (for < 120 ms)	
External fuse recommendation		
Current rating (12V/24V input)	4.5 A (min)	2 A (min)
I ² t value (12V/24V input)	5.2/1.3 A ² s (min)*	5.2/1.3 A ² s (min)*
* degraded for 10.000 pulses		* degraded for 10.000 pulses
Interfaces		
CAN		
Type	CAN ISO 11898-2, 2.0B, (High Speed CAN)	
Driver	MAX13053ESA	
Baud Rate	Configurable 20 – 250 kbit/s, optional up to 1 Mbit/s	
USB		
Type	Host, V 2.0	
Speed	Full speed, max 12 Mbit/s	
Host port	5 V, max 500 mA, over-current and short-circuit protected	
Ethernet		
Type	According to 10BASE-T and 100BASE-TX standards *	
Isolation voltage	500 V _{AC} /707 V _{DC}	
* With deviation from required isolation where 10BASE-T and 100BASE-TX states 1500 V(AC) isolation.		
Serial		
Type	RS-232	
Max speed	Up to 230 kbps	
Signals present	Rx, Tx, CTS, RTS, GND	
Protection	Galvanically isolated, 550 V _{DC}	
Video In		
Supported input signals	Composite video, PAL (B, D, G, H, I, M, N, Nc) and NTSC (J, M, 4.43)	
Power outputs	4 software controllable outputs.	
Output Voltage	12 V _{DC}	
Output Current	Up to 0.5 A total (sum of all outputs)	
Protection	Video inputs are ESD protected. Video power outputs are short-circuit- and overcurrent protected.	
Audio out		
	Stereo line out	
Line out level	1 V _{RMS} into 10 kΩ	
Protection	Audio outputs are ESD- and short-circuit protected.	
A	GPS	
Type of receiver	NMEA-0183	
Antenna type	Active, 3.0-3.3 V DC, max 40 mA	
Antenna gain	0 to +30 dB, including cable loss (+10 to +25 dB preferred)	
A	GPRS	
Frequency Band	Quad band GPRS modem (band (850/900/1800/1900 MHz)	
GPRS class	Class 10	

AT commands	3GPP TS 27.005, 27.007
Output power	Class 4 (2 W) @ 850/900 MHz, Class 1 (1 W) @ 1800/1900 MHz
Antenna type	Depending on frequency ranges provided by network operator.
Antenna gain	1.4 dBi at 850 MHz (max) 3.0 dBi at 1900 MHz (max)



WLAN

IEEE Standard	IEEE 802.11 b/g
Data Rate	Up to 54 Mbps
Range	Up to 100 m
Antenna type	Monopole, omnidirectional
Antenna gain	3.0 dBi (max)



Bluetooth

Type	Bluetooth 2.1 + EDR, Class 1
Range	Up to 100 m
Antenna type	Dipole, omnidirectional
Antenna gain	2.14 dBi (max)

HMI

Status LED	Tricolor LED status indicator with configurable behaviour. Flashes yellow during start-up and shutdown.
------------	--

Software

Operating system	Linux
Additional software	CCsettings, CCvideo. API's are available to access system specific settings from software applications. Refer to the <i>CCpilot XA Software guide</i> for details.



Display

7" (CCpilot XA models)

Type	TFT, 16:9
Resolution	WVGA, 800x480
Colour depth	24 bit
Backlight	LED, 400 cd/m ²
Touch-screen type	Projective Capacitive (PCAP)

10.4" (CCpilot XS models)

Type	TFT, 4:3
Resolution	XGA, 1024x768
Colour depth	24 bit
Backlight	LED, 450 cd/m ²
Touch-screen type	Resistive

7.3. Environmental specifications

Environmental Test	Standard	Notes
Dry Heat	IEC 60068-2-2:2007	Operating: +70°C, 24h Storage: +85°C, 24h
Damp Heat	IEC 60068-2-30:2005	Operation: +25°C / +55°C >93% RH 6*24h
Cold	IEC 60068-2-1:2007	Operating: -25°C, 24h Storage: -40°C, 24h
Change of temperature	IEC 60068-2-14:2009	-25°C to +30°C, 5C/min 3hr hold time, 20 cycles
Vibration	IEC 60068-2-64:2008	0,01 g2/Hz 10-200 Hz 3x0.5h
Shock	IEC 60068-2-27:2009	5 g / 11ms 3x ±1000 bumps
EMC Electrical Transient	ISO 7637-2:2011	Pulse 1: -50V 3b: +35V 2: +25V 4: -5V 3a: -35V 5: +70V
EMC Immunity, ESD	EN 61000-4-2:2009	8 kV air, 6 kV contact
	ISO 10605:2008	4 kV air, 4 kV contact
EMC RF Immunity, Radiated ¹⁾	ISO 11452-2:2004	RF electromagnetic field 200-1000MHz, 60V/m
	EN 61000-4-3:2006+A1+A2	RF electromagnetic field 80M-1GHz 10V/m 1G-2GHz 3V/m 2G-2,7GHz 1V/m
EMC RF Immunity, Induced ¹⁾	ISO 11452-4:2005/Cor.1:2009	Bulk Current Injection 20-200MHz, 120 mA
	EN 61000-4-6:2009	0.15-80 MHz, 10V
EMC Radiated Emission ¹⁾	ISO 14982:2009	Narrow b. Broad b. [dBµV/m] [dBµV/m]
		MHz 30-75 54-44 64-54 75-400 44-55 54-65 400-1000 55 65
	EN 61000-6-2:2005 EN 61000-6-4:2007+A1:2011	MHz [dBµV/m] 30-230 40 QP, 10 m 230-1000 47 QP, 10 m 1000-3000 76 pk, 56 avg, 3 m 3000-6000 80 pk, 60 avg, 3 m
EMC Burst	EN 61000-4-4:2004+A1	±2 kV DC , ±1 kV signal
EMC Surge	EN 61000-4-5:2006	±0.5 kV DC, ±1 kV signal
Enclosure Ingress Protection	IEC 60529:1989+A2:2013	IP65
Low Voltage Directive ²⁾	EN 60950-1:2006	
Radio transmitters ²⁾	Article 3.2 (Radio) - EN 301 511 v9.0.2 - EN 300 328 v1.7.1 Article 3.1b (EMC) - EN 301 489-7 v1.3.1 - EN 301 489-17 v2.1.1	Each radio module is individually tested for radio performance compliance by respective module manufacturer. EMC is tested on device level.

¹⁾ Requires shielded cables for Ethernet, USB and Video interfaces.

²⁾ All-Integrated versions only, for compliance to the R&TTE directive.

Environmental tests are performed at 24 V_{DC} supply voltage unless otherwise required. The environmental tolerance may be affected by external factors like mounting, omitting the use of shielded cables etc.



Any changes or modifications to the device not expressly approved by maximatecc could void the environmental classification, warranty as well as user's authority to operate the equipment.



7.4. Weight and dimensions

Observe that illustrations below show the *All-Integrated* models. Labeling and amount of connectors differs from the *standard* models.

7.4.1. CCpilot XA (7")

	Description	Comments
Dimensions	227 x 130 x 52.7 mm	(W x H x D)
Weight	1.04 Kg	Applies to the <i>Standard</i> variant, not the <i>All-Integrated</i> variant shown in the illustration below.
Mounting holes Spacing	VESA 50	-
Thread dimension	50 mm	
Thread depth	M5	
	9.5 mm	

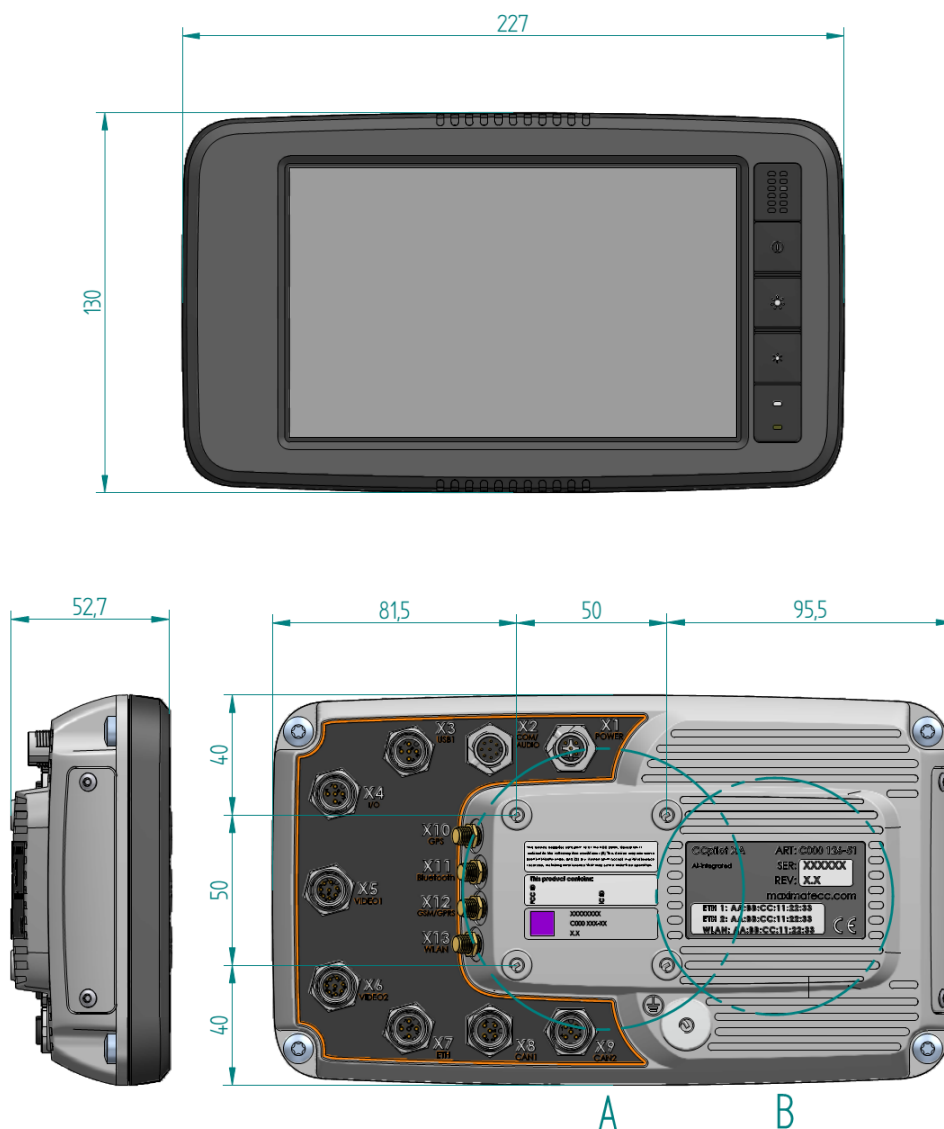

7.4.2. CCpilot XS (10.4")

	Description	Comments
Dimensions	215 x 278 x 69.2 mm	(W x H x D)
Weight	2.2 Kg	Applies to the <i>Standard</i> variant, not the <i>All-Integrated</i> variant illustrated below.
Mounting holes	VESA 50	-
Spacing	50 mm	
Thread dimension	M5	
Thread depth	9.5 mm	

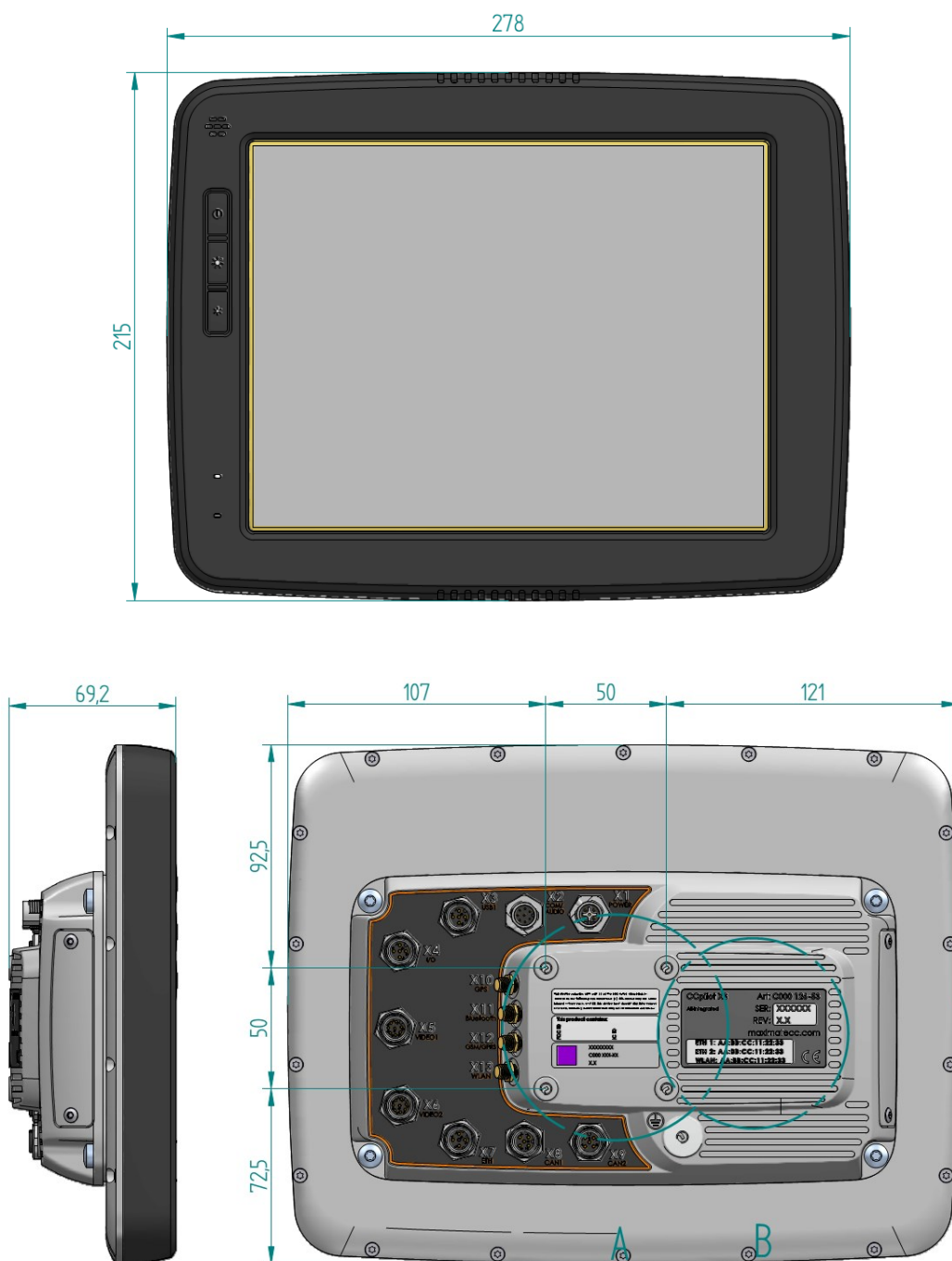

7.4.3. CrossCore XS

	Description	Comments
Dimensions	259 x 130 x 46.2 mm	(W x H x D)
Weight	1.25 Kg	Applies to the <i>Standard</i> variant illustrated below, not the <i>All-Integrated</i> variant.
Mounting holes	4 x Ø 8.5 mm	

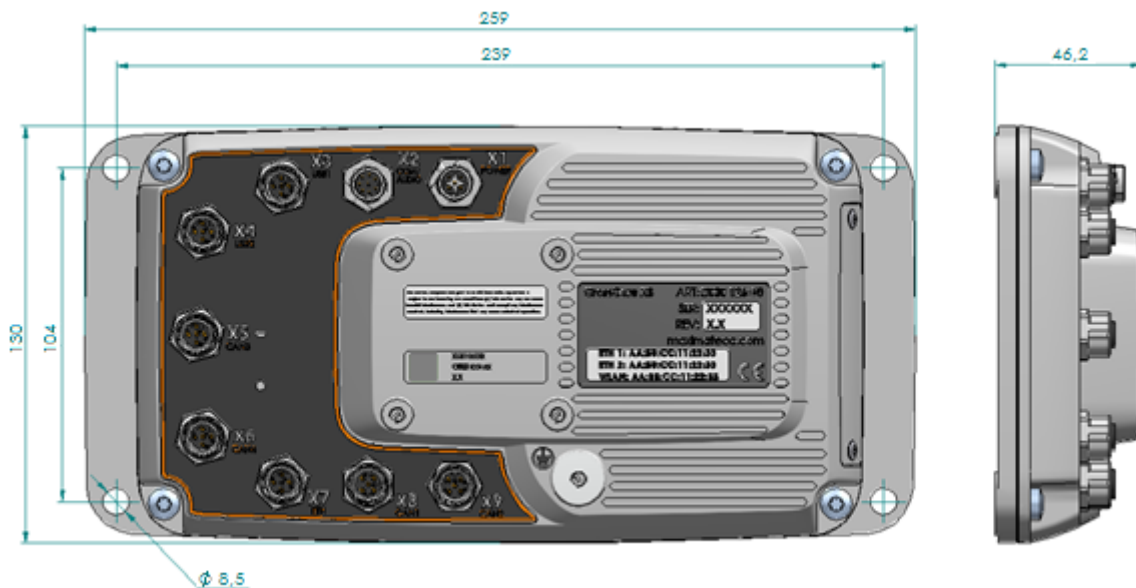

The illustration below shows the orientation of cables with right-angled M12 connectors attached to the device:

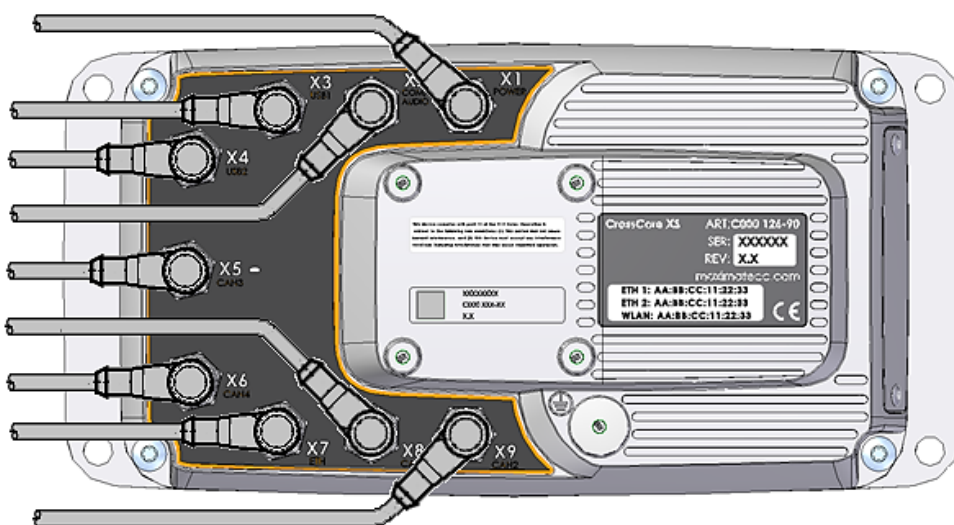

8. Technical Support

Contact your reseller or supplier for help with possible problems with your device. In order to get the best help, you should have your device in front of you and be prepared with the following information before you contact support.

- Part number and serial number of the unit, which you find on the brand label.
- Date of purchase, which is found on the invoice.
- The conditions and circumstances under which the problem arises.
- Status LED indicator flash patterns.
- Possible error messages which are shown.
- Operating system type and its version number.
- The device log files (if possible).
- Prepare a system report on the device, from within *CCsettings* (if possible).
- Information regarding possible external equipment which is connected to the device.

9. Trade Mark, etc.

© 2013 maximatecc

All trademarks sighted in this document are the property of their respective owners.

CCpilot is a trademark which is the property of maximatecc AB.

Freescale is a registered trademark of Freescale Semiconductor Inc. ARM is a registered trademark of ARM Limited. Linux is a registered trademark of Linus Torvalds. Bluetooth is a trademark of Bluetooth SIG. CANopen is a registered trademark of CAN in Automation (CiA).

maximatecc is not responsible for editing errors, technical errors or for material which has been omitted in this document. maximatecc is not responsible for unintentional damage or for damage which occurs as a result of supplying, handling or using of this material including the devices and software referred to herein. The information in this handbook is supplied without any guarantees and can change without prior notification.

For maximatecc licensed software, maximatecc grants you a license, to under maximatecc intellectual property rights, to use, reproduce, distribute, market and sell the software, only as a part of or integrated within, the devices for which this documentation concerns. Any other usage, such as, but not limited to, reproduction, distribution, marketing, sales and reverse engineer of this documentation, licensed software source code or any other affiliated material may not be performed without written consent of maximatecc.

maximatecc respects the intellectual property of others, and we ask our users to do the same.

Where software based on maximatecc software or products is distributed, the software may only be distributed in accordance with the terms and conditions provided by the reproduced licensors.

For end-user license agreements (EULAs), copyright notices, conditions, and disclaimers, regarding certain third-party components used in the device, refer to the copyright notices documentation.

10. Index

A

Analog video connectors.....	24
Analog video inputs.....	20
Antennas.....	13
Audio.....	19
Audio connector.....	24

B

Basic operations.....	16
Battery.....	11, 15
Bluetooth.....	22
Bluetooth antenna connector.....	25
Brightness.....	17
Buttons.....	16, 17
Buzzer.....	19

C

Cable installation.....	13
CAN.....	20
CAN connectors.....	25
Care.....	15
Cleaning.....	15
Connectors.....	23, 27
Contact support.....	34

D

Device overview.....	7
Digital I/O.....	21
Digital I/O Connector.....	24
Dimensions.....	31
Double-click.....	17

E

Environmental specifications.....	30
Environmental tests.....	30
Environmental Tolerance.....	6
Ethernet.....	20
Ethernet connector.....	25
External interfaces.....	23

F

Flash.....	19
Forced shutdown.....	17
Fuse.....	11

G

GMS/GPRS antenna connector.....	26
---------------------------------	----

GoreTex.....	14
GPS.....	21
GPS antenna connector.....	25
GSM/GPRS.....	22

H

Handling.....	15
Handling.....	10

I

Indicators.....	18
Inputs.....	23
Installation.....	10
Installing cables.....	13
Introduction.....	4

L

LED.....	18
Light sensor.....	19

M

Maintenance.....	15
Memory.....	19

O

ON/OFF.....	11
Outputs.....	23

P

Pinouts.....	23
Pins.....	23
Ports.....	23
Power supply connector.....	23
Power supply installation.....	11
Product models.....	27

R

Right-click.....	17
RS-232.....	21

S

SD-card.....	19
Serial port.....	21
Serial port connector.....	24
Shutting down.....	16
SIM card installation.....	13
Size.....	31

Specifications	27
Starting Up	16
Storage	19
Support	34

T

Technical data	27
Technical Support	34
Test standards	6
Thread depth	10
Touch screen	17
Touchscreen	17
Trade Mark	35
Turning off	16

Turning on	16
------------------	----

U

USB	20
USB connectors	24

V, W

Weight	31
Video inputs	20
WLAN	22
WLAN antenna connector	26