

# CCpilot VS 12”

## Technical Manual



## Contents

<b>Revision history</b> .....	<b>3</b>
<b>1. Introduction</b> .....	<b>4</b>
1.1. Document conventions .....	4
1.2. Identification .....	4
1.3. Environmental resistance .....	4
<b>2. Device overview</b> .....	<b>5</b>
2.1. Front side view .....	5
2.2. Rear side view .....	6
2.3. Left side view .....	6
<b>3. Mounting and handling</b> .....	<b>7</b>
3.1. Mounting .....	7
3.2. Connecting to power supply .....	7
3.3. Cable installation .....	9
3.4. Special considerations .....	9
3.5. Handling and maintenance .....	10
3.6. Transportation .....	11
<b>4. Basic operation</b> .....	<b>11</b>
4.1. Turning ON/OFF .....	11
4.2. Light sensor .....	12
4.3. Using the touch screen .....	12
4.4. Status notification .....	12
4.5. Error codes .....	13
<b>5. Interface overview</b> .....	<b>14</b>
5.1. Front panel .....	14
5.2. Buzzer .....	14
5.3. Analog video input .....	14
5.4. CAN .....	15
5.5. Ethernet .....	15
5.6. USB .....	15
5.7. Analog input .....	16
5.8. Configurable input .....	16
5.9. High-side outputs .....	17
5.10. RS-232 .....	18
5.11. RS-485 .....	18
5.12. Key switch signal .....	18
<b>6. Connectors</b> .....	<b>18</b>
6.1. Deutsch DT connectors, general .....	19
6.2. Deutsch DT connector A pinout .....	20
6.3. Deutsch DT connector B pinout .....	20
6.4. Deutsch DT connector C pinout .....	20
6.5. M12 connectors, general .....	21
6.6. USB M12 connector pinout .....	21

6.7. Ethernet M12 pinout ..... 21

6.8. USB Type A connectors, general ..... 22

6.9. USB Type A pinout ..... 22

**7. Specifications ..... 22**

7.1. Technical data ..... 22

7.2. Environmental specifications ..... 26

7.3. EMC specification ..... 26

7.4. Weight and dimensions ..... 27

**Technical support ..... 29**

**Trademarks and terms of use ..... 29**

**Index ..... 30**

## Revision history

Rev	Date	Author	Comments
A	2017-11-23		Released
1.1.0	2018-09-14		Revision matched with product revision

# 1. Introduction

*CCpilot VS* is a display computer with a 12" widescreen high-resolution TFT and PCAP touch screen. The strong LED backlight in combination with the optically bonded PCAP, results in excellent sunlight readability properties.

The powerful Arm® based main CPU and Linux® operating system constitute an open platform that facilitates the implementation of premium user-machine interaction, reliable controls and integrated fleet management solutions. In addition, there is one co-processor responsible for hardware control and supervision.

This technical manual provides important information regarding the device's hardware and its basic usage. For software and operating system specifics, please see additional documentation.

## 1.1. Document conventions

This document uses the following conventions:

### Description

Important information

### Appearance



(exclamation symbol)

Text formats used in this document are described in the table below:

Format	Use
<i>Italics</i>	<i>Names, designations, and references</i>
<b>Bolded</b>	<b>Important information</b>

## 1.2. Identification

Each device has an identification label with serial number, article number and revision which identify your unique device. Take note of these numbers. During service and other contact with the supplier it is important to be able to provide this information.

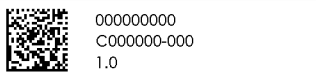

Figure 1: Identification label

## 1.3. Environmental resistance

The *CCpilot VS 12"* device has been designed to manage tough environmental demands. Much effort has been put into designing and selecting system components to provide a reliable and robust device.

Thorough testing has been performed in order to ensure compliance to a broad range of applicable regulatory requirements and to meet the user expectations of a ruggedized device for machinery control.

A complete list of standards to which the device has been tested for compliance can be found in chapters 7.2 and 7.3.

## 2. Device overview

This chapter contains illustrations of the *CCpilot VS 12"* showing the location of external connectors, indicators etc. Connectors are described in more detail in chapter 6. Additional mechanical information can be found in chapter 7.4.

### 2.1. Front side view

At the front side of the device there is a 12" widescreen display with a projected capacitive touch-sensor (PCAP).

There is a light sensor in the front panel which enables automatic dimming of display.

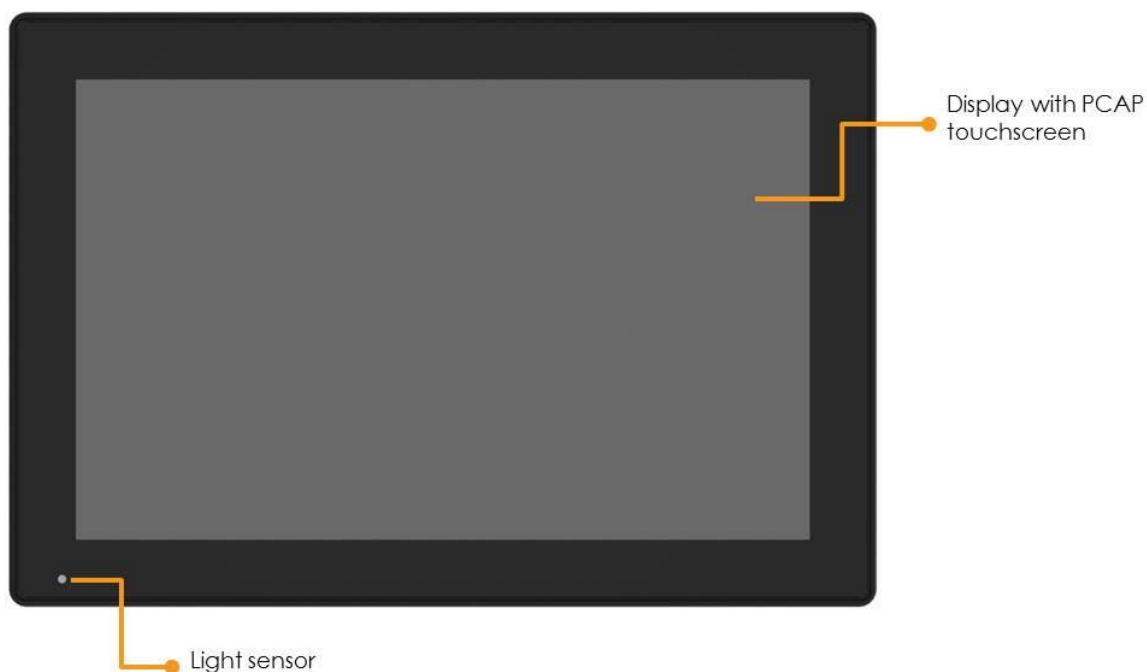

*Figure 2: CCpilot VS front side view*

## 2.2. Rear side view

At the rear side of the device there are interface connectors, i.e. 3x Deutsch DT connectors, 2x M12 USB connectors and a M12 Ethernet connector.

There are also four M5 threaded inserts for mounting the device to a VESA75 mount.

Finally, there is a combined sound exit hole and ventilation membrane.

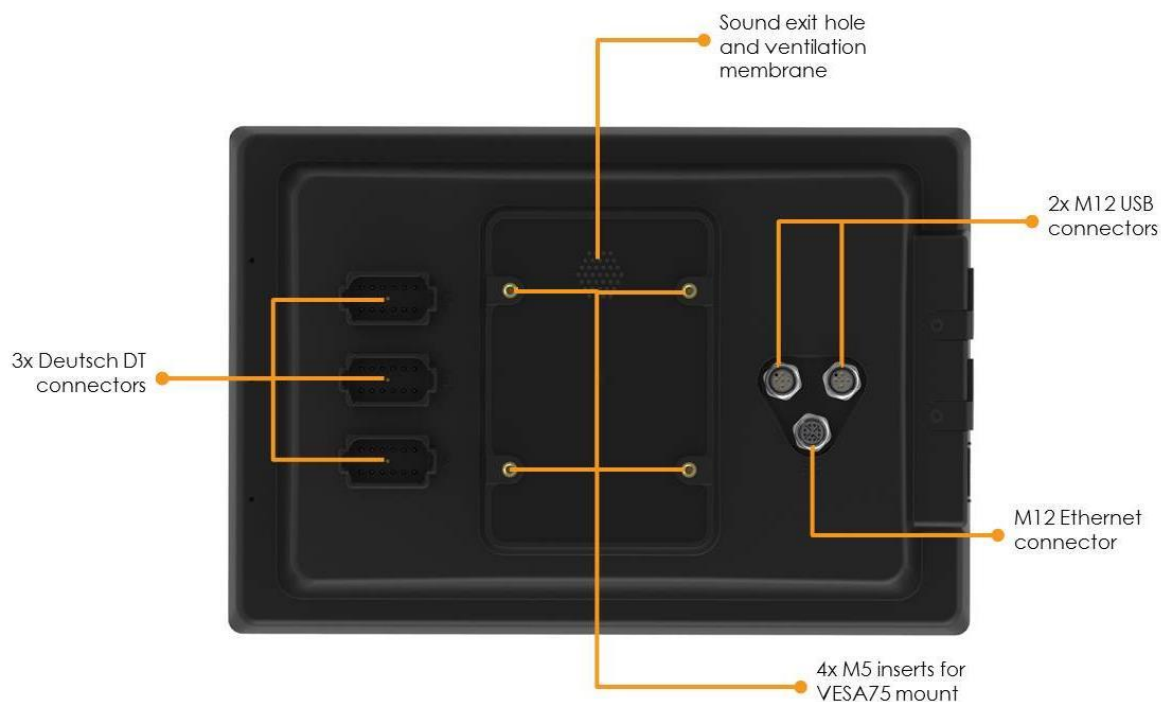

Figure 3: CCpilot VS rear side view

## 2.3. Left side view

On the left side of the device there is an on/off button with a built-in RGB status LED as well as two USB type A connectors, placed under dust-protecting lids.

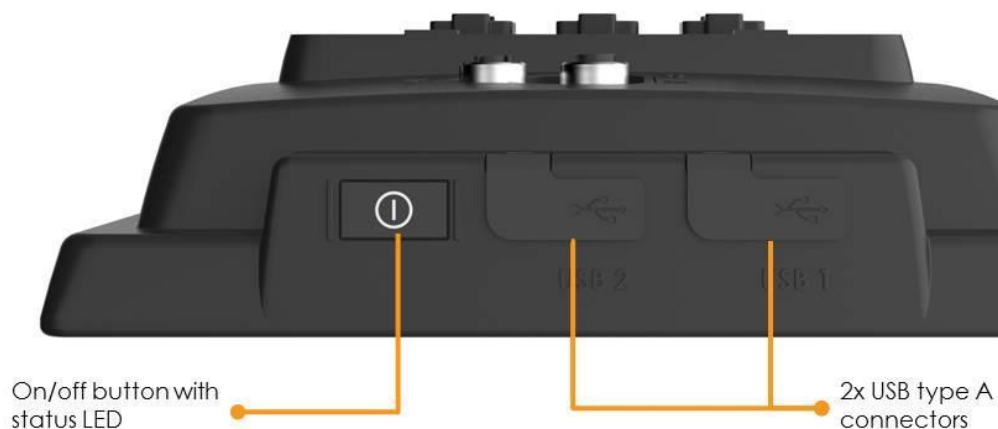

Figure 4: CCpilot VS left side view

## 3. Mounting and handling

This chapter contains recommendations for installation, handling and maintenance of the device.

### 3.1. Mounting

*CCpilot VS 12"* supports a standardized VESA75 mounting interface.

It is recommended to use 4 pc. M5 x 0.8 Allen screws, with a length of 12 mm. The recommended fastening torque is 1.5 - 2.0 Nm. Using fluid locker or locking washers (split ring, toothed lock, etc.) is required for proper mounting. Ensure that the M5 mounting screws are clean and dry before mounting.



Note that the depth of the threaded holes is 8 mm. Be careful not to use too long screws which may damage the device when tightened.

### 3.2. Connecting to power supply

This chapter describes how the *CCpilot VS* is preferably connected to the power supply of the vehicle. The principle is the same also for other types of installations.



Carefully read through the following sub-chapters before installing the device. Connector pinouts are found in chapter 6.

#### 3.2.1. Wire gauge

Wire gauge for the power supply should be dimensioned with respect to the start current at cranking.

- Current consumption of the *CCpilot VS 12"* device is found in chapter 7.1.
- Power consumption of external loads driven by the *CCpilot VS 12"* device should also be taken into account.
- The wire gauge for the power supply is recommended to be at least 1.5 mm<sup>2</sup> /AWG 15 for "normal" loads and at least 2.5 mm<sup>2</sup> /AWG 14 if using high external loads.
- The DT connectors accept wire gauges between 0.75 and 3.3 mm<sup>2</sup> /AWG 12 to 18.

#### 3.2.2. External fuse



To prevent cable fire in case of short circuit, an external fuse must always be used when powering the device from a high current capable power source, for example a vehicle battery.

- The fuse shall be located as close to the battery/power source as practically possible.
- Fuse rating shall be dimensioned with respect to wire gauge, maximum current consumption and the inrush current of the device. Refer to chapter 7.1 for fuse rating details.
- As a guideline, a slow acting fuse with 15 A current rating should be used.
- Remember to also apply fusing for the on/off control wiring, see chapter 3.2.4.

### 3.2.3. External key switch signal

The device's key switch signal should be connected to the positive supply line via the vehicle's ignition key switch.

- The wire gauge for the key switch signal shall be dimensioned to handle the total switch current and the fuse type and rating shall be selected to prevent cable fire in case of cabling short circuit.
- As a guideline, a slow acting fuse in the range of 100-500 mA for the key switch signal should be sufficient for most practically usable wire gauge.

### 3.2.4. Application example

Below is an application example schematic of the *CCpilot VS 12"* power supply connection.

If the system has a main switch for completely disconnecting the battery (S1 in schematic below), the device's power supply and key switch signal shall be connected after the main switch.



It is **not** recommended to disconnect the battery without shutting down the device first - since doing so will immediately switch off all internal voltages, regardless of ongoing operations. Any information which was not saved to flash memory will be lost when disconnecting the battery. However, no physical damage will be caused to the device by disconnecting the battery.

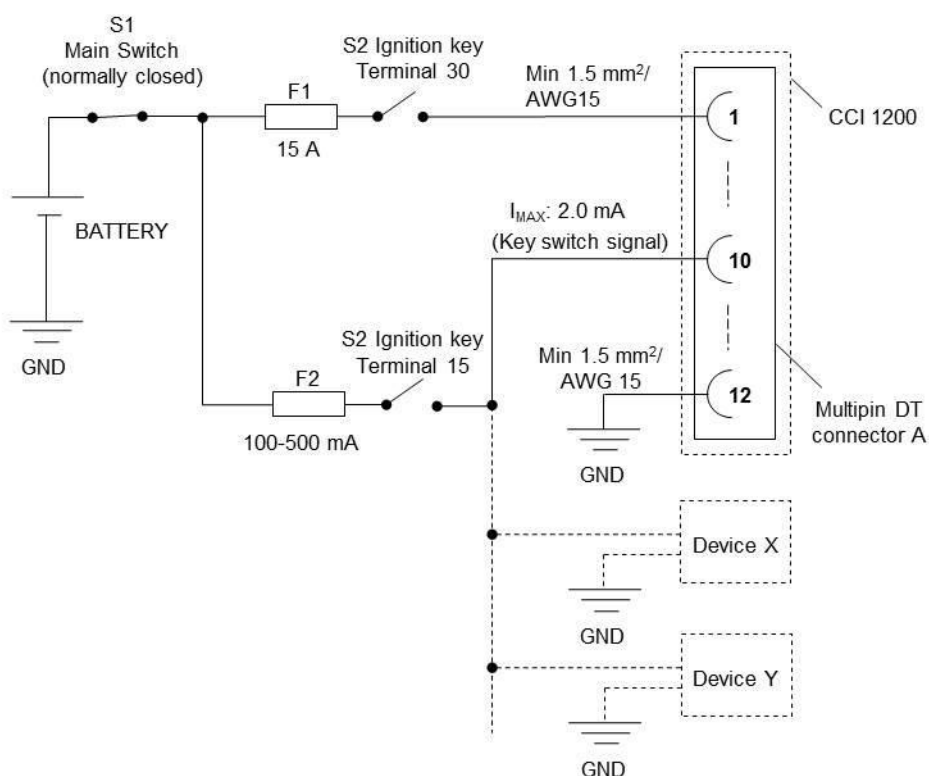

Figure 5: Schematic example for power supply installation of a *CCpilot VS 12"* device in a vehicle. The ignition switch (S2) can be shared by several devices (Device X, Y, ...)

By connecting the power supply according to the example above, the *CCpilot VS 12"* device will automatically start up when the key switch (S2) is closed and shut down when the switch is opened.





Note that the on/off behavior of the *CCpilot VS 12"* described here is the default configuration. Its response to the on/off signal may be altered using the CCAux API, see chapter 4.1 for more details.

### 3.3. Cable installation

Cables shall be installed in such a way that they don't run any risk of being damaged, pinched or worn.

- Avoid excessive bending and twisting of cables.
- Use strain-relief on cables near the device to minimize stress on cables and connectors.
- Properly snap the connectors to give reliable contact and sealing and to avoid unnecessary strain.
- Shielded cables are recommended and in some cases necessary to ensure reliable communication and appliance with agricultural EMC standards.

#### 3.3.1. Recommendations for cable shields and coaxial cables



To achieve electromagnetic compliance and stable operation of the system, shielded cables are required for Ethernet and USB interfaces. In addition, it is recommended to use 75  $\Omega$  coaxial cables for connecting analog video sources to the device.

When using shielded cables for Ethernet, the shield is preferably connected/grounded at the other end of the cable (and remain unconnected close to the *CCpilot VS 12"* device).

When using shielded cables for the M12 USB ports, the shield is preferably spliced and joined with the USB connector's shield. Avoid creating ground-loops in the USB cable by insulating any attached USB-devices from ground structures connected with the *CCpilot VS 12"* device.

Below are recommendations for inserting cable shields and coaxial cables into Deutsch DT plugs to achieve robust connections and retaining IP classification of the device.

- Splice the cable shield (or coaxial inner and outer conductors) outside of the DT plug and use regular, round cables for insertion into the plug.
- Minimize distance between cable joints and the DT plugs for best shielding effect.

### 3.4. Special considerations



To ensure proper and reliable operation and to retain IP-classification of the device, below recommendations must be followed:

- The device should be placed in a way that prevents direct exposure to water or close proximity to hot-air vents.
- To enable sufficient cooling, the device must be installed in a way that allows ambient air to circulate around it. A clearance of at least 50 mm around the device is recommended.
- To maintain IP classification, all three Deutsch DT connectors must be attached to the device. Blind plugs must be used for unconnected pins. Please note that the protective caps mounted on the DT connectors are for transportation protection only. The rubber sealing of the USB-ports on the left side of the device must also be properly attached when not using the USB-ports.

- The device has a ventilation membrane, refer to Figure 3 for the location. For proper ventilation of the device, dirt and water must be prevented from accumulating and covering the membrane. Be cautious not to insert objects which may puncture the membrane. Doing so will violate the IP-classification and void the warranty of the device.
- Install the device and any cables attached such that they are not subject to excess vibrations or other potentially harmful stress.
- Loose fasteners are a common cause for excessive vibration. Fasteners may come loose due to improper mounting techniques such as omitting thread lockers (fluid locker or locking washers) or by over/under-tightening. Proper tightening requires dry, clean fasteners and a torque wrench.
- If the device is exposed to chemicals, water, dirt or other pollutants, it's recommended to have it cleaned off as soon as possible. See chapter 3.5.1 for cleaning instructions.

### 3.5. Handling and maintenance



Handle the device with care and pay attention to the following handling instructions:

- Disconnect all cables to the device during welding or when performing other service to the machine imposing a risk of damaging electronic devices.
- Service and repair to the device shall only be made by authorized personnel. If the device is opened by unauthorized personnel, its warranty will be void.
- Scratches or other damages may occur to the display surface if it is exposed to sharp objects, abrasives or heavy impacts. This must be avoided to increase the longevity of the screen.
- The internal eMMC flash storage has a limited number of write cycles. Therefore it is recommended that the amount of writing to flash is limited within software applications.<sup>1</sup>
- Always consider personal safety when installing and operating the device. For example, in vehicle installations, CrossControl does not recommend that the device is being actively operated by the driver when a risk of injury to people or damage to property is present.

#### 3.5.1. Cleaning



To ensure proper and reliable functionality over time, pay attention to the following cleaning instructions and precautions:

- Wipe the device clean from dirt using a soft damp cloth, preferably of microfiber type. Larger amount of dry dust may be swept off using a soft brush before wiping clean.
- Avoid using alkaline, alcoholic or other potentially adverse chemicals for cleaning as doing so may damage the device. However, small amount isopropyl alcohol may be used for removing harsh stains.

---

<sup>1</sup> The eMMC is used in pseudo SLC mode and implements both static and dynamic wear levelling to reach the best reliability. The number of program/erase cycles is between 20k to 60k depending on the manufacturer and temperature. Our recommendation for the application software is to temporary cache in RAM and to write larger chunks of data to the eMMC. This recommendation is not specific to eMMC but is applicable to all flash memories.

- Avoid spraying or by other means applying larger amount of water or alcohol directly to the device. Instead, lightly dampen a cloth before using it for cleaning the device.
- After cleaning, make sure that the device surface is left dry.
- Never use high-pressure air, vacuum, water or steam to clean the device.

### 3.5.2. Real time clock battery



Time and date information is stored in a memory sustained by an internal back-up battery.

The expected life time of the battery is approximately 20 years. The battery is not replaceable.

## 3.6. Transportation

When transporting the device it is recommended to use the original packaging. Make sure that protective caps are used on all non-mated connectors. The storage temperature interval [-30°C to +80°C] must be met.

## 4. Basic operation

This section covers basic operation of the device such as start-up, shut-down, display operation and status notification.



Observe that the behavior of the on/off controls (on/off button and key switch signal) is user configurable.

Button backlight is used for status notification while starting up, shutting down or when the device is in rescue mode. Both button backlight and the buzzer is software controllable for notifications from user applications.

See chapter 4.4 for details of button backlight status notification.

The buzzer is used for audible alerts as well as for various error notifications, see chapter 4.5 for error code details.

### 4.1. Turning ON/OFF

The device can be turned ON or OFF from different actions as described in the following chapters.



To avoid data loss or corrupted flash memory, it is recommended that necessary data is saved and user applications are properly closed before the device is shut down.

#### 4.1.1. Key switch signal

The factory default way of turning the device ON or OFF is by the use of the vehicle's ignition switch.

Turning the vehicle's ignition key to position ON will start the device.

Turning the vehicle's ignition key to position OFF will turn off the device.

#### 4.1.2. On/off button

While in off-state, pressing and holding the on/off button will turn ON the device.

While the device is operating, pressing and holding the on/off button for 1 sec will turn OFF the device.

#### 4.1.3. Linux shutdown command

The device can be turned OFF by executing Linux shell shutdown commands, for example:

```
# shutdown
```

#### 4.1.4. Forced shutdown

If the device stops responding, a forced shutdown can be performed by pressing and holding the on/off button until the device is switched off.

- The button press response time for the forced shutdown (*long press*) is user configurable and the default value is set to 8 seconds.



It is **not** recommended to use the forced shut down unless absolutely necessary - since doing so will immediately switch off all internal voltages, regardless of ongoing operations. Any information which was not saved to flash memory will be lost when performing a forced shutdown. However, no physical damage will be caused to the device by a forced shutdown.

## 4.2. Light sensor

The *CCpilot VS 12"* contains a light sensor that can be used to automatically adjust the display brightness, depending on the ambient light conditions. As depicted in Figure 2, the light sensor is located in the lower left corner of the front surface. When automated dimming is enabled, the level of sensitivity can be adjusted.

The screen brightness can also be manually controlled directly from user applications through APIs.



For proper operation it is important to keep the light sensor opening clean and with free visibility.

## 4.3. Using the touch screen



To reduce the amount of reflections when operating under sunny conditions, the touch screen's protective glass is covered with an anti-glare film. Do not use any sharp or abrasive objects when interacting with the touch screen.

Basic usage of the capacitive touch screen should be intuitive for most users. Note that the touch screen is capable of handling two simultaneous touches.

## 4.4. Status notification

The LED in the on/off button is used for status notification while starting up, shutting down or in other operational states. The buzzer may also be used for user notifications. See Table 1 for a description of the status notification behavior for different operational states.

Table 1: LED and buzzer indication for different operational states

Operational state	LED indication	Buzzer notification
Device off	OFF	-
Power applied, device off	OFF	-
Starting up	Yellow flashing, 2 Hz	Short beep
Operating (started up)	Static green	-
Shutting down	Static green	-

Forced shutdown	Blue flashing, 2 Hz	short beep
Rescue mode, starting	Static orange	Short beep
Rescue mode, running	Green flashing, 2 Hz	
Software upgrade	Yellow flashing, 0.5 Hz	-

#### 4.5. Error codes

The LED in the on/off button is also used for indicating error codes by emitting a blue blinking pattern after shutdown of the device. The device may be started again when in this mode, by the button or the key switch signal. Depending on the nature of the error, the device may start or go back into error indication.

When an error occurs, the device is immediately shut down and the error is reported by blinking a specific number of times corresponding to an error code (see table of error codes). The blinks will be in a continuous sequence of 1 Hz blinks, with a longer pause of two seconds after the specific number of blinks, allowing the end user to count the number of blinks. Refer to Figure 1 below for an example.

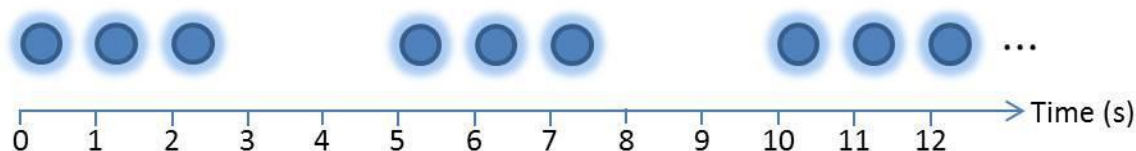

Figure 6: Example of the blinking pattern for error code 3

When an error occurs, an error code is also immediately saved to persistent storage (FRAM). If several errors occur before the device it is shut down, only the code of the first error is saved and reported. The error code in persistent storage can be read and cleared from a user application. Refer to Table 2: CCpilot VS 12" error codes for a complete listing of the error codes.

The number of blinks is important information if the unit is sent in for service/repair.

Table 2: CCpilot VS 12" error codes

Error code	Error code name	Likely problem cause
1	errCodeReadErrEEPROM	Corrupted FRAM. Invalid values. FRAM may need to be manually reprogrammed or replaced.
2	errCodeWriteErrEEPROM	Corrupted FRAM. Invalid values. FRAM may need to be manually reprogrammed or replaced.
3	errCodeDriverInit	FRAM or light sensor malfunction. Problem with cable to button/USB PCB.
4	-	-
5	errCodeMPDoneTimeoutErr	Timeout waiting for the MP_DONE signal – MP error. Boot loader missing. Faulty or unprogrammed eMMC.
6	errCodeTimeOutWaitingForVoltages	Internal or external voltages did not stabilize during start-up. Power supply current limitation. Power cables not thick enough (>1.5 mm <sup>2</sup> ).
7	errCodeTEMPOutOfLimits	Internal PCB temperature above 95 °C or temperature sensor malfunction
8	-	-
9	-	-
10	errCodeRCCLInit	SS circuit malfunction (clocks).

11	errCodeSSState	Programming bug or faulty processor.
12	errCodeManageDiagnostics	Failed to save diagnostic data to FRAM.
13	errCodeManageActDeAct	HAL_IO errors (SS internal).
14	errCodeTickTimeOutTimer	HAL_IO errors (SS internal).
15	errCodeOperateModeStateError	SS internal.
16	errCodeHALIOReadErr	HAL_IO errors (SS internal).
17	errCodeHALIOWriteErr	HAL_IO errors (SS internal).
18	-	
19	-	
20	-	
21	-	
22	-	
23	-	
24	-	
25	errCode12VOutOfLimits	Internal 12V voltage out of limits during operation.
26	errCode5VOutOfLimits	Internal 5V voltage out of limits during operation.
27	errCode3V3AOutOfLimits	Internal 3V3A voltage out of limits during operation.

## 5. Interface overview

This section describes the various interfaces of the device. Main part of these interfaces can be accessed via software APIs. These are described in the *CCpilot VS 12" Software Guide*.

### 5.1. Front panel

#### 5.1.1. Touch screen

The front panel contains a projective capacitive (PCAP) touch screen, which is capable of handling two simultaneous touches.

#### 5.1.2. Light sensor

There is a light sensor in the front panel used by user applications or used with the built in automated function for dimming of the display brightness.

For light sensor location, see Figure 2. Refer to the *CCpilot VS 12" Software guide* for details about accessing the light sensor data from user applications.

### 5.2. Buzzer

There is a built-in buzzer that can be used for audible notifications. The buzzer is software controllable with configurable volume and frequency.

For buzzer location see Figure 3. See chapter 4.4 for buzzer notification events. Refer to the *CCpilot VS 12" Software guide* for details about controlling the buzzer from user applications.

### 5.3. Analog video input

There is a video input for connecting an analog video source such as a rear-view camera. Displaying of analog video is handled in hardware with minimum impact on CPU load.

The analog video input supports a wide range of commonly used composite video formats (both PAL and NTSC).

See chapter 7.1 for details.



For proper video performance and to ensure electromagnetic compatibility, 75  $\Omega$  coaxial cable shall be used for connecting the video source. Preferably use coaxial cables of type M17/94-RG179. Refer to chapter 3.3.1 for recommendations about connecting video coaxial cable.

It is important to supply the analog video source with a stable well-filtered supply voltage. Note that video input grounds are internally connected with main supply ground. Precautions should be made to avoid ground-loops between the video source and main supply ground which could affect video quality. One way of avoiding ground-loop is to add video isolators or use a video source with galvanic isolation between supply and signal ground.

### 5.4. CAN

*CCpilot VS 12"* has four CAN ports, supporting ISO 11898 CAN 2.0B protocol (29-bit extended identifier) and bit rates up to 1 Mbps.

*CCpilot VS 12"* is compliant with AEF ISO 11783.



Note that Internal EMI filters on CAN High/Low signals have a capacitance of 100 pF (typ) which deviates from the ISO 11898 standard and implies some limitations on the CAN bus topology (maximum bus length, number of CAN nodes etc.) when running at high bit-rates, i.e. above 250 kbps.

The ports feature highly protected CAN transceivers which are tolerant for bus short-circuits to main supply voltage and ground.

CAN shield connections are according to J1939-11 with capacitive coupling to ground. There is no device-internal CAN bus termination, therefore bus termination must be applied externally.

### 5.5. Ethernet

*CCpilot VS 12"* has an Ethernet interface supporting 10BASE-T/100-BASE-TX/1000-BASE-T and Auto-MDIX.

The Ethernet interface is galvanic isolated with 1.0 kV<sub>AC</sub> insulation voltage.

Shielded cables shall be used to ensure reliable communication and electromagnetic compliance.



As with all Ethernet enabled devices, connecting the device to a public network environment may impose an IT security threat.

### 5.6. USB

*CCpilot VS 12"* has in total four USB ports; two ports are located in the M12 connectors 3 and 4 at the rear of the device, and two ports are located in the USB type A connectors on the left side, refer to Figure 3 and Figure 4 for localization of the ports. They can be used for connecting USB storage devices or other peripherals such as mouse, keyboard or various wireless interfaces. All USB-ports are capable of both full-speed (12 Mbps) and hi-speed (480 Mbps) communication.



Note that the sealing property (IP classification) of the device is not retained when removing the protective rubber lids for accessing the USB ports on the left side.

Each USB ports can supply up to 2A. The USB ports are internally over-current and short-circuit to ground protected.

Shielded cables shall be used to ensure reliable communication and electromagnetic compliance. Refer to chapter 3.3.1 for recommendations about connecting shield cables.

## 5.7. Analog input

CCpilot VS 12" has one fixed analog input 0-14V range with 12.7 kΩ input impedance to ground.

## 5.8. Configurable input

CCpilot VS 12" has one configurable input for a wide range of digital and analog measurements. This input can be configured according to Table 3 below.

Table 3: Input configurations

Input modes		Configurations
<b>Digital input modes</b>		
Digital input	Range	0-10V
	Input configurations	Pull-down (ca 14 kΩ to GND)
		Pull-up (ca 4,7 kΩ to $V_{in}$ and 14 kΩ to GND)
	Input modes	Mode 1
		High level ca 3,4 V
Mode 2		low level ca 1,5 V
		High level ca 6,3 V
Frequency measurement	Range	0.1-10 000 Hz
	Input configurations	Pull-down (ca 14 kΩ to GND)
		Pull-up (ca 4,7 kΩ to $V_{in}$ and 14 kΩ to GND)
	Input modes	Mode 1
		High level ca 3,4 V
Mode 2		low level ca 1,5 V
		High level ca 6,3 V
<b>Analog input modes</b>		
Voltage measurement	Range	0-32V

For electrical specification at different input modes, see chapter 7.1.



Note that the input ground is internally joined with main supply ground. Precautions should be made to avoid ground-loops between input ground and main supply ground. Ground-loop currents may affect readings.

The co-processor handles the configurable input and adds features such as averaging for frequency measurements. Measurement results are accessible to user applications through software APIs. Refer to the *CCAux API documentation* for programming details. Each input mode is described more in chapters 5.8.1 and 5.8.2 below.



### 5.8.1. Digital input and frequency measurement

Digital and frequency input modes can be used for connecting simple logical signals (for example switch to battery/ground or various logic output sensors) or frequency-output sensors commonly used in industrial applications.

The input can be configured for two different logic signal levels thresholds and can be set as either pull-down only or internal pull-up (together with the pull-down). This makes the input compatible with a wide range of sensors with different output types and signal levels.

The selectable internal pull-up is sourced from the main supply input through internal over-voltage protection. Therefore, pull-up will follow the main supply voltage but never exceed  $55 V_{DC}$  in case of main voltage transients.

Frequency measurement is implemented by timer captures at a time-base of 72 MHz (100 ppm). This time-base gives a theoretical frequency resolution of approximately 0.014 Hz at 1 kHz and 3.12 Hz at 15 kHz (better resolution at lower frequencies). Refer to the *CCAux API documentation* for details about available configurations.

See chapter 7.1 for electrical characteristics such as absolute maximum voltage, digital threshold levels, pull-up strength, frequency range and accuracy.

### 5.8.2. Voltage measurement

The input can be used for measuring DC-voltages in range of 0-32 V.

See chapter 7.1 for electrical characteristics such as impedance and accuracy.

## 5.9. High-side outputs

CCpilot VS 12" has six self-protected high-side digital outputs for switching various external loads such as buzzers, relays, solenoids, lamps or other resistive or inductive loads.

The high-side output drivers are powered from the main supply voltage through internal over-voltage protection that limits the output voltage to  $50 V_{DC}$  (typ) in case of supply voltage transients. Four of the outputs are specified for 400mA load and two are specified for 800mA load, but all use the same technical solution. Each output is current-limited to 1200 mA per channel (typ).

Each output provides diagnostics/fault-detection for both ON- and OFF-state according to Table 4 below.

Table 4: Diagnostics and fault detection for high-side outputs

OFF-state	ON-state
Open load	-
Short to battery	-
-	Overload or short to ground
-	Over-temperature

To ensure long-term reliability, the fault-detection flags are continuously monitored and each output is automatically switched OFF in case its fault flag is triggered in ON state. An output switched OFF by a fault condition must be re-enabled by the user or user application.



Observe that high continuous load of the outputs generates internal heat in the device. At high ambient temperatures, this may lead to outputs automatically switching off because of thermal protection. Outputs can be re-enabled by the user (or user application) once the driver IC

temperature has decreased below its threshold. If output over-temperature shutdown occurs, it is recommended to improve air ventilation around the device and if possible reduce the amount of output load.

Output on/off control as well as fault monitoring is handled by a co-processor and controlled through CCAux API.

See chapter 7.1 for electrical characteristics such as channel resistance, timing, current limit, and fault-detection details.

### **5.10. RS-232**

*CCpilot VS 12"* has two RS-232 ports, each supporting communication rates up to 115200 bps.

See *chapter 7.1* for electrical characteristics such as protection voltages.

### **5.11. RS-485**

*CCpilot VS 12"* has one RS-485 port, supporting communication rates up to 115 kbps.

The RS-485 configuration in *CCpilot VS 12"* comprises one A/B pair, i.e. full-duplex communication is not supported.

See *chapter 7.1* for electrical characteristics such as protection voltages.

### **5.12. Key switch signal**

To simplify the cable harness design, *CCpilot VS 12"* has two input pins reserved for the key switch signal. These pins are connected internally, i.e. any of the pins can be used. Refer to chapter 6.2 and 6.3 for pinout details.

## **6. Connectors**

All external connectors are accessible from the rear or left side of the device.

The main connectors are the three 12-pin Deutsch DT series connectors, marked with letters A, B and C and features keying (A-, B- and C-key respectively). The DT connectors are located to the left of the rear side. To the right of the rear side there are three M12 connectors, marked with 3, 4 and Eth. Finally, on the left side of the device there are two USB type A connectors marked 1 and 2. These USB connectors are protected under a rubber sealing. Refer to Figure 7 for an overview of the connectors.



Figure 7: CCpilot VS 12" connectors

Connector pinouts are found in the following chapters.

### 6.1. Deutsch DT connectors, general

- ! Use caution and avoid plugging/unplugging Deutsch DT connectors while the device is powered up. If a connector pin becomes bent the interface may not function correctly and the device should be returned to the manufacturer for repair.
- ! Pay close attention to the coding; violence or excessive force should not be used when mating the connectors.
- ! Note that the pin-order 1-12 in tables below are oriented as when looking at the receptacles from the rear of the CCpilot VS 12" device, i.e. pin 1 at *top-left* position and pin 12 at *bottom-left* position, see Figure 8.

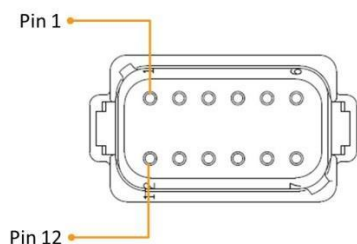

Figure 8: DT connector pinout

The connector pins are rated for 13 A continuous current.

- ! The DT connector pins are made of tin-plated brass. It is recommended to use tin-plated receptacles in the mating connectors. Using different plating in the cable connectors might cause galvanic corrosion.
- ! Note that all three Deutsch DT connectors must be mated with its corresponding cable connector or a proper blind plug to maintain the IP-classification.

## 6.2. Deutsch DT connector A pinout

Table 5: DT connector A pinout

DT Connector A		
Matching plug: DT06-12SA (A-key)		
Pin	Signal	Comment
1	Power supply	12 V or 24 V, see chapter 3.2.4 for information on connection
2	High side output 1	(max 800 mA load)
3	High side output 2	(max 400 mA load)
4	CAN1 high	
5	CAN1 low	
6	CAN1 ground	
7	CAN2 high	
8	CAN2 low	
9	CAN2 ground	
10	Key switch signal	See chapter 3.2.4 for information on connection
11	Not connected	
12	Ground	

## 6.3. Deutsch DT connector B pinout

Table 6: DT connector B pinout

DT Connector B		
Matching plug: DT06-12SB (B-key)		
Pin	Signal	Comment
1	High side output 3	(max 800 mA load)
2	CAN3 high	
3	CAN3 low	
4	CAN3 ground	
5	CAN4 ground	
6	Analog input	
7	Key switch signal	See chapter 3.2.4 for information on connection
8	Ground	
9	Configurable input	
10	CAN4 high	
11	CAN4 low	
12	Ground	

## 6.4. Deutsch DT connector C pinout

Table 7: DT connector C pinout

DT Connector C		
Matching plug: DT06-12SC (C-key)		
Pin	Signal	Comment
1	High side output 4	Video supply (max 400 mA load)
2	Video IN	
3	Video shield	Internally connected to supply ground
4	RS-485B	
5	RS-485A	
6	High side output 5	(max 400 mA load)
7	Spare	
8	Spare	

9	High side output 6	RS-232 supply	(max 400 mA load)
10	RS-232 2 TxD		
11	RS-232 2 RxD		
12	Ground		

## 6.5. M12 connectors, general



Pay close attention to the coding; violence or excessive force should not be used when mating the connectors. The connectors are oriented so that an angled cable should be pointing downwards. Refer to Figure 9 for pin orientation.

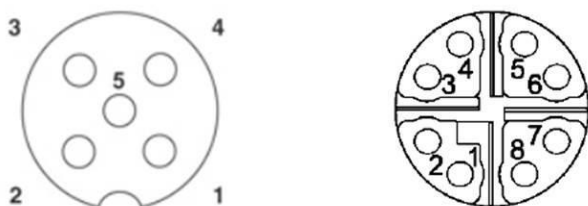

Figure 9: M12 connector pinout, A-coded to the left and X-coded to the right



The M12 connector pins/receptacles are made of gold-plated copper-zinc alloy. It is recommended to use gold-plated pins/receptacles in the mating connectors. Using different plating in the cable connectors might cause galvanic corrosion. The M12 contact body is made of polyamide and the sleeve around it is made of nickel-plated zinc.



Note that all three M12 connectors must be mated with its corresponding cable connector or a proper blind plug to maintain the IP-classification.

## 6.6. USB M12 connector pinout

Table 8: USB M12 connector pinout

USB M12 Connector	
Matching plug: SACC-M12MS-5CON-PG 7-SH (male, 5-pin, A-coded)	
Pin	Signal
1	VBUS
2	Data-
3	Data+
4	Ground
5	Ground

## 6.7. Ethernet M12 pinout

Table 9: Ethernet M12 connector pinout

Ethernet M12 Connector	
Matching plug: SACC-MSX-8QO SH ETH SCO (male, 8-pin, X-coded)	
Pin	Signal
1	TR0+
2	TR0-
3	TR1+
4	TR1-
5	TR3+
6	TR3-

7	TR2-
8	TR2+

## 6.8. USB Type A connectors, general



USB type A connectors do not meet the *CCpilot VS 12"* IP-classification unless the rubber lid is closed. There is an inner sealing to prevent water and dust to enter the device via the USB type A connectors. However, the connector itself might be damaged by water and dust, so make sure the rubber lids always are closed when not using the connectors.

If the rubber lids should be damaged contact the supplier for replacement parts.

## 6.9. USB Type A pinout

Table 10: USB type A connector pinout

USB type A Connector	
Matching plug: male, 4-pin, type A	
Pin	Signal
1	VBUS
2	Data-
3	Data+
4	Ground

# 7. Specifications

## 7.1. Technical data

Temperature specification	
Operating	-30 to +70 °C
Storage	-30 to +80 °C

Kernel	
Main Processor	NXP™ i.MX6: ARM 32-bit, 1 GHz, Automotive, Quad core, Cortex®-A9
Co-processor	STMicroelectronics STM32F373, Cortex®-M4
Data storage	4 Gbyte, Industrial grade eMMC <sup>(Note)</sup>
RAM memory	2 Gbyte, DDR3



Note: The eMMC is used in pseudo SLC mode and implements both static and dynamic wear levelling to reach the best reliability. The number of program/erase cycles is between 20k to 60k depending on the manufactures and temperature. Our recommendation for the application software is to temporary cache in RAM and to write larger chunks of data to the eMMC. This recommendation is not specific to eMMC but is applicable to all flash memories.

Power Supply	
Supply voltage	
Nominal	12 V <sub>DC</sub> or 24 V <sub>DC</sub>
Extreme	7.5 V <sub>DC</sub> ...32 V <sub>DC</sub>

### Power consumption

	<b>V<sub>in</sub> = 12 V<sub>DC</sub></b>	<b>V<sub>in</sub> = 24 V<sub>DC</sub></b>
Typical, operating	17 W (typ)	17 W (typ)
Max, operating	143 W max	230 W max
Device without ext loads	17 W max	17 W max
4x USB @ max load	40 W max	40 W max
6x HS out @ max load	86 W max	173 W max
Shutdown	0.44 mA	(typ) 0.85 mA (typ)

### Inrush current

	<b>V<sub>in</sub> = 12 V<sub>DC</sub></b>	<b>V<sub>in</sub> = 24 V<sub>DC</sub></b>
Duration ca 60 ms	< 8.5 A	< 4.5 A

### External fuse recommendation

Current rating	15 A* (including maximum external loads)
----------------	--

\* This assumes that the fuse is in accordance with IEC 20127 i.e. can be continuously operated at 100% of rated current.

### CAN interfaces

Type	Non-isolated, ISO 11898-2, CAN 2.0B with cable shield decoupling according to J1939-11. Supports ISOBUS
CAN transceiver	NXP TJA1051T/3
Baud Rate	20 – 250 kbps (up to 1 Mbps)* * Internal CAN bus filters have a capacitance of 100pF (typ) as stated in the J1939 specification. This puts restrictions on the CAN bus topology considering bus length, number of CAN nodes etc. when running at bit-rates higher than 250 kbps.
Protection	Short circuit protected to -32V to +32V

### USB interfaces

Type	4x USB 2.0 compatible host ports Two USB ports are available in M12 connectors, the remaining ports are USB type A connectors covered by a removable rubber sealing. Device IP-classification is not retained when the USB sealing is removed.
Speed	Full-speed (12 Mbps) and Hi-speed USB (480 Mbps) is supported.
VBUS supply	According to USB specification, but with increased drive capacity 5.0 V, 2 A per port, internally over-current and short-circuit protected.

### Ethernet

Type	Gigabit Ethernet compatible with 10BASE-T, 100BASE-TX and 1000Base-T Ethernet standards. Auto-MDIX support.
Insulation voltage	1000 V <sub>AC</sub> , 50/60Hz for 1 minute.

### Analog video

Number of inputs	1
Supported input signals	Composite video 75 ohm, PAL and NTSC
Protection	Video inputs are over-voltage protected up to +40 V <sub>DC</sub> .

Configurable Inputs	
Number of inputs	1
Input voltage tolerance	+32.0 V (max), referred to main supply ground - 32.0 V (min), referred to main supply ground (inputting voltages greater than specified may damage the device)
Digital input levels mode 1	applies to both Digital and Frequency modes
Rising threshold	3.4 V (typ)
Falling threshold	2.5 V (typ)
Hysteresis	0.9 V (typ)
Digital input levels mode 2	applies to both Digital and Frequency modes
Rising threshold	6.3 V (typ)
Falling threshold	1.5 V (typ)
Hysteresis	4.8 V (typ)
Frequency measurement	Input amplitude ranges according to above.
Frequency range	0.1 Hz – 10 kHz
Duty-cycle range	40-60% Exceeding above duty-cycle limits may cause inaccurate readings.
Time base	72 MHz (± 100 ppm)
Accuracy	± 0.50 % (typ) up to 15 kHz Input jitter (pulse time variations) will affect accuracy, especially at high frequencies.
Input impedance with pull-up enabled	4.7 kΩ (± 2 %) to main supply voltage and 14.04kΩ (± 2 %) to ground.
Input impedance with pull-up disabled	14.04kΩ (± 2 %) to ground.
Voltage measurement	
Range (min)	0 – 32.0 V <sub>DC</sub>
Accuracy	± (2% + 40 mV)
Resolution	8 mV
Input Impedance	14,04kΩ (± 2 %)



High-side digital outputs	
Number of channels	6
Current limit	
Initial peak current	1200 mA (typ) (min 700 mA, max 2000 mA) per channel
Repetitive short-circuit	1000 mA (typ).
Diagnostics	Built-on diagnostics and fault flag monitoring. To ensure long-term reliability, the fault flags are continuously monitored and each output is automatically switched OFF in case the fault flag is triggered in ON state.
OFF state diagnostics	Open load, short to battery
ON state diagnostics	Over-load (or short to GND), over-temperature
Open-load detection	
Internal pull-up current	5 $\mu$ A (typ)
Threshold voltage	2.0 V (typ) (min 1.5V, max 3.5V) Open load is detected when output voltage rises above the threshold voltage in OFF state.
Short-circuit detection	
Voltage threshold	2.8 V (typ) Over-current is detected when output voltage falls below the threshold voltage in ON state.
Over-temp. detection	
Turn-off Threshold	+175 $^{\circ}$ C typ (min 150 $^{\circ}$ C, max 200 $^{\circ}$ C)
Hysteresis	10 $^{\circ}$ C
ON-state resistance	400 m $\Omega$ (typ), 700 m $\Omega$ (max)
Slew rate	
Turn ON:	80 $\mu$ s (typ), 180 $\mu$ s (max)
Turn OFF:	80 $\mu$ s (typ), 200 $\mu$ s (max)
OFF-state leakage	5 $\mu$ A (typ) 12 $\mu$ A (max)

Buzzer	
Frequency range	1 – 20 kHz (SPL peak at 3200 Hz)
SPL	85 dBA at 1 meter (typ, 3200 Hz) The buzzer is located on the back (connector side) of the device and the effective SPL varies dependent on the acoustic properties of the installation environment.

Button and Status notification	
On/off button	On/off button with backlight and tactile feedback.
Status notification	Button backlight is used for status notification, such as blinking at 2 Hz during start-up, etc.

Software	
Operating system	Yocto Linux, Kernel version 4.1.38
Additional software	CCAux API. Refer to the <i>CCpilot VS Software Guide</i> and <i>Programmer's guide</i> for details.

Display	
Size	
Diagonal size	12.1 inch widescreen
Active area	261.12 x 163.2 mm
Pixel pitch	204 x 204 µm
Type	
Aspect ratio	16:10
Resolution	WXGA, 1280x800
Colour depth	24 bit (16.7 million colors)
Contrast ratio	450:1 (min), 700:1 (typ)
Viewing angle	Horizontal: ± 80° Vertical: -60° -- +80°
Backlight	
Type	LED
Brightness	1080 cd/m <sup>2</sup> (min), 1350 cd/m <sup>2</sup> (typ)
LED Life time	80 000 h (min), 100 000 h (typ) before brightness is reduced with 50 % (when operated with full brightness at 25 °C) <small>(Note that higher operating temperatures affects LED life time.)</small>
Touch-screen	
Type	Optically bonded
Simultaneous touches	Projective capacitive touch panel (PCAP)
Protective glass thickness	2
Coating	1.8 mm
Surface Hardness	Clear and CS (chemically strengthened)
	5H

## 7.2. Environmental specifications

Environmental Test	Test standard	Notes
Dry Heat	IEC 60068-2-2:2007	Operating: +70°C, 24h Storage: +80°C, 16h
Damp Heat	IEC 60068-2-30:2005	Operation: +25°C / +55°C >90% RH 2*24h
Cold	IEC 60068-2-1:2007	Operating: -30°C, 24h Storage: -30°C, 24h
Change of temperature	IEC 60068-2-14:2009	-30°C to +70°C, 5°C/min 3hr hold time, 20 cycles
Vibration	IEC 60068-2-64:2008	0.005 g <sup>2</sup> /Hz 10 Hz 0.005 g <sup>2</sup> /Hz 260 Hz 0.002 g <sup>2</sup> /Hz 350 Hz 3x8h
Shock	IEC 60068-2-27:2008	± 15 g / 11ms 3x1000 impulses
Enclosure Ingress Protection	IEC 60529:2014	IP65



Any changes or modifications to the device not expressly approved by CrossControl could void the environmental classification, warranty, and user's authority to operate the equipment.

## 7.3. EMC specification

The *CCpilot VS 12"* device has been tested for Electromagnetic Compatibility according to the following standards.

EMC Test	Test standard	Notes
----------	---------------	-------

		<b>Pulse</b>	<b>Level</b>	
Electrical Transients	ISO 7637-2:2011 12 V system	1	-25V	
		2	+25V	
		3a	-25V	
		3b	+25V	
		4	-4V	
		5	+26,5V, Ri = 2Ω	
	24 V system	1	-450V	
		2a	+37V	
		2b	+20V	
		3a	-150V	
3b		+150V		
	4	-12V		
	5	+123V, Ri = 2Ω		
ESD immunity	ISO 10605:2008, EN 61000-4-2	Air Contact	± 8 kV ± 6 kV	
Radiated RF immunity <sup>(1)</sup>	ISO 11452-2:2004	<b>MHz</b> 200-2000	<b>Level</b> 30 V/m	<b>Modulation</b> 80%AM, 1kHz
Induces RF immunity <sup>(1)</sup>	ISO 11452-4:2005/Cor.1:2009 (BCI)	<b>MHz</b> 20-200	<b>Level</b> 60 mA	<b>Modulation</b> 80%AM, 1kHz
Radiated RF emission <sup>(1)</sup>	ISO 13309:2010	<b>MHz</b> 30-75	<b>Narrow-b.</b> dBμV/m 54-44	<b>Broad-b.</b> dBμV/m 64-54
		75-400	44-55	54-65
		400-1000	55	65

(1) Compliance to RF immunity and RF emission standards require use of shielded cables for Ethernet, USB and Video interfaces.

EMC tests are performed at 24 V<sub>DC</sub> supply voltage unless other levels are specified in test standards.

System level compliance to EMC standards may be affected by external factors like mounting, omitting the use of shielded cables etc.

## 7.4. Weight and dimensions

Attribute	Description	Comments
Dimensions	312 x 213 x 66 mm	(W x H x D)
Weight	2.0 kg	
Mounting holes	VESA75	
Spacing	75 mm	
Thread dimension	M5	
Thread depth	8 mm	
Enclosure material	Glass fiber reinforced polyamide	

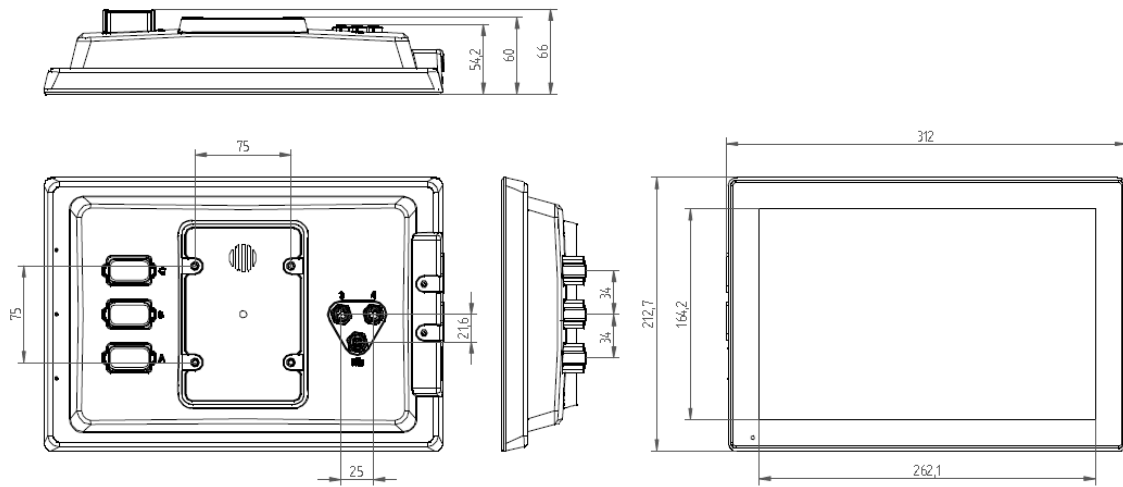

Figure 10: CCpilot VS dimensions.

## Technical support

Contact your reseller or supplier for help with possible problems with your device. In order to get the best help, you should have your device in front of you and be prepared with the following information before you contact support.

- Part number and serial number of the unit, which you find on the identification label, see Figure 1.
- Date of purchase, which is found on the invoice.
- The conditions and circumstances under which the problem arises.
- Error codes signaled by the status LED
- Possible error messages which are shown.
- Device log files (if possible).
- Information regarding possible external equipment which is connected to the device.
- Additional sources of information are available on the CrossControl support site: <http://support.crosscontrol.com>

## Trademarks and terms of use

© 2017 CrossControl

All trademarks sighted in this document are the property of their respective owners.

- NXP™ is a trademark of NXP Semiconductors Inc.
- Arm® is a registered trademark of ARM Limited.
- Linux® is a registered trademark of Linus Torvalds in the U.S. and other countries.
- CrossControl and CCpilot are trademarks of CrossControl AB.

CrossControl is not responsible for editing errors, technical errors or for material which has been omitted in this document. CrossControl is not responsible for unintentional damage or for damage which occurs as a result of supplying, handling or using of this material including the devices and software referred to herein. The information in this handbook is supplied without any guarantees and can change without prior notification.

For CrossControl licensed software, CrossControl grants you a license under CrossControl intellectual property rights to use, reproduce, distribute, market and sell the software, only as a part of or integrated within, the devices for which this documentation concerns. Any other usage, such as, but not limited to, reproduction, distribution, marketing, sales and reverse engineer of this documentation, licensed software source code or any other affiliated material may not be performed without written consent of CrossControl.

CrossControl respects the intellectual property of others, and we ask our users to do the same. Where software based on CrossControl software or products is distributed, the software may only be distributed in accordance with the terms and conditions provided by the reproduced licensors.

For end-user license agreements (EULAs), copyright notices, conditions, and disclaimers, regarding certain third-party components used in the device, refer to the copyright notices documentation.

## Index

- Ambient light sensor, 12, 14
- Analog input, 16
- Analog video, 14, 23
- Application example, 8
- Backlight, 26
- Basic operation, 11
- Battery, 11
- Button, 11, 25
- Buzzer, 14, 25
- Cable installation, 9
- CAN, 15, 23
- Care, 10
- Cleaning, 10
- Clock, 11
- Coaxial cables, 9
- Configurable input, 16, 24
- Connectors, 18
- Contact, 29
- Conventions, 4
- CPU, 22
- Device overview, 5
- Digital input, 16
- Dimensions, 27
- Display, 26
- Document conventions, 4
- DT connector A pinout, 20
- DT connector B pinout, 20
- DT connector C pinout, 20
- DT connectors, 19
- Electrical specifications, 22
- EMC specification, 26
- eMMC, 22
- Environmental resistance, 4
- Environmental specifications, 26
- Error codes, 13
- Ethernet, 15, 23
- Ethernet M12 pinout, 21
- Example, 8
- External interfaces, 18
- Forced shutdown, 12
- Frequency measurement, 16
- Front panel, 14
- Front side view, 5
- Fuse, 7
- Fuse recommendation, 22
- Glass, 26
- Handling, 7, 10
- High-side outputs, 17, 25
- I/O, 16, 17, 24
- Identification, 4
- Ignition key, 8, 11, 18
- Inputs, 16, 18, 24
- Inrush current, 22
- Installation, 7, 9
- Interface overview, 14
- Introduction, 4
- ISOBUS, 23
- Key switch, 8, 11, 18
- Left side view, 6
- Light sensor, 12, 14
- Linux shutdown command, 12
- M12 connectors, 21
- Maintenance, 10
- Mounting, 7
- On/Off button, 11
- Operating temperature, 22
- Operation, 11
- Outputs, 17, 18, 25
- Overview, 5
- PCAP, 12, 14, 26
- Pinout, 20, 21, 22
- Ports, 18
- Power consumption, 22
- Power supply, 7, 22
- Protective glass, 26
- RAM memory, 22
- Rear side view, 6
- RS-232, 18
- RS-485, 18
- RTC, 11
- Shields, 9
- Shutdown, 11
- Size, 27
- Software, 25
- Special considerations, 9
- Specifications, 22
- Start-up, 11
- Status notification, 12, 25
- Storage, 22
- Support, 29
- Technical data, 22
- Technical support, 29
- Temperature specification, 22
- Terms of use, 29
- TFT, 26
- Touch screen, 12, 14, 26
- Trademarks, 29
- Transport, 11

Turning OFF, 11  
Turning ON, 11  
USB, 15, 23  
USB M12 connector pinout, 21  
USB type A connectors, 22  
USB type A pinout, 22

Weight, 27  
Video, 23  
Video input, 14  
Wire gauge, 7  
Voltage, 22  
Voltage measurement, 17